



*An Online CPD Course
brought to you by
CEDengineering.ca*

Design and Sizing of Baghouse Dust Collectors

Course No: D06-005
Credit: 6 PDH

Anuj Bhatia



Continuing Education and Development, Inc.

P: (877) 322-5800
info@cedengineering.ca

DESIGN AND SIZING OF BAGHOUSE DUST COLLECTORS

Introduction

Industrial dust collection systems or the air pollution control equipment (APC) can be broadly classified as - Fabric filters, Inertial separators, and Electrostatic precipitators.

Fabric Filters

The fabric filters capture dust particles and various other particles by impaction, direct interception, and diffusion when the contaminated gas stream passes through the fabric material. Fabric filters are most suitable for removing particles of size 0.1 -1 μm . Such filters are usually made from cotton, wool, synthetics, or glass fiber. These include systems like baghouses and cartridge collectors.

Inertial Separators

Inertial separators are dust collectors that don't use filters and instead rely on gravity and inertia to collect dust. They remove dust from gas streams using inertia, then deposit it into a storage hopper using gravity. They are most effective at removing the coarser dust particles from contaminated air. Examples of prominent inertial separators include cyclone dust collectors, multi-cyclone dust collectors, settling chambers, and baffle chambers.

Electrostatic Precipitators

Electrostatic precipitators work using ionization principle. They give particles a negative charge and then attract them out of the air stream by means of a positively charged electrode. To remove disposed of dust particles, electrostatic precipitators either continuously rap against them or continuously vibrate until they fall into a bin. The combustible nature of many fine materials rules out the use of electrostatic precipitators.

Other miscellaneous dust collecting systems include wet dust collectors, small dust collectors, portable dust collectors, downdraft tables and shop vacuums.

Types of Dust Collection Systems

Baghouse Filters

Baghouses remove dust and other particulates by passing the gas stream through filter bags made up of a long hollow cylindrical tube. The baghouse contains large number of such filter bags arranged in parallel rows. They are very efficient and effective, with a collection rate of over 99% for fine particles.

Cartridge Dust Collectors

Cartridge dust collectors are a small and compact type of dust collector. They can filter very small (sub-micron) particulates very efficiently. The filter media is usually a felted material composed of cellulose, polypropylene, or other flex-resistant material. These are typically used for industries such as metalworking that generate small particulates, smoke, and fumes.

Cyclone Dust Collectors

Cyclone dust collectors, or simply cyclones, remove particulate particles from a gas stream using the principle of inertia. The dusty airstream is forced to flow in a tangential path through a conical shaped chamber. This results in centrifugal action which throws the heavier particles in the gases to the outer wall of the chamber and fall to the bottom where they are collected. Cyclones are good at removing large particles but not so good at removing smaller ones. As a result, they are utilised in conjunction with other particle control devices.

Settling Chambers

Settling chambers slow down the flow of air, allowing heavier particles to settle out more quickly. They are common elements of pre-cleaning procedures. This includes the pre-cleaning of air streams before they enter dust collectors, such as baghouses that remove extra fine dust particles.

Baffle Chambers

Baffle chambers create a barrier that causes the air to abruptly shift directions, causing the heavier particles to fall to the bottom of the chamber due to their inertia. For example, the HVAC air intake system in desert regions use sand trap filters which contain baffles.

Wet Scrubbers

Wet scrubbers are specialized downdraft tables and unit dust collectors that use liquids (usually water) to intercept dust particles from the stream of gas. Wet scrubber technique is also used in some air pollution control equipment, where it removes soot, smog, and fine chemical pollution from the air of industrial facilities on a molecular level.

Shop Vacuums

Shop vacuums are commercial vacuum cleaners that pull in wet or dry air using centrifugal fans. Inside, they collect and hold onto contaminants, dust, and fumes cyclonically or with a fabric bag filter. Shop vacs are usually canister shaped.

When compared to other forms of Air Pollution Control (APC) equipment, baghouse dust collectors are incredibly versatile and can be constructed for practically any dust-producing application by varying size and bag types. They are very efficient when properly maintained and are also rugged enough to handle rough applications.

This course will cover the Fabric Type Baghouse Filter.

TABLE OF CONTENTS

1 CHAPTER -1: OVERVIEW OF BAGHOUSE FILTERS..... 7

1.1 Design Parameters..... 8

1.2 Cleaning Mechanism..... 10

1.3 Baghouse Efficiency 10

1.4 Standard Products..... 11

2 CHAPTER -2: BAGHOUSE TYPES..... 13

2.1 Mechanical Shaker Baghouse 13

2.2 Reverse Air Baghouse..... 14

2.3 Pulse Jet Baghouse 16

2.4 Cartridge Filters..... 18

2.5 Selection Criteria..... 19

3 CHAPTER -3: BAGHOUSE DESIGN CONSIDERAIONS 20

3.1 Design Parameters..... 20

3.2 Airflow Rate..... 20

3.3 Air Velocity 21

3.4 Typical Air to Cloth (A/C) Ratios..... 22

3.5 Bag Spacing..... 23

3.6 CAN Velocity..... 26

3.7 Baghouse Compartment Design..... 28

3.8 Baghouse Pressure Drop (ΔP)..... 29

3.9 Controls and Instrumentation 29

4 CHAPTER - 4: BAGHOUSE COMPONENTS..... 32

4.1 Collection Hood 32

4.2 Ductwork..... 32

4.3 Filter Medium..... 33

4.4 Collection Hopper 33

4.5 Discharge Device 33

4.6 Fan..... 33

5 CHAPTER -5: GUIDELINES FOR YOUR COLLECTION HOODS..... 34

5.1 Design Objective 34

5.2 Effectiveness of the Hood System 34

5.3	System Design.....	35
5.4	Capture Velocity	35
5.5	Rate of Airflow.....	36
5.6	Hood Opening and Shapes	36
5.7	Hood Position.....	38
5.8	Hood Entry Loss and Static Pressure	38
5.9	Good Practices.....	40
6	CHAPTER – 6: GUIDELINES FOR YOUR DUCTWORK.....	41
6.1	Types of Industrial Ductwork	41
6.2	Conveying Velocities	41
6.3	Duct Sizing Calculations	42
6.4	Duct Materials	43
6.5	Duct Shapes.....	44
6.6	Duct Static Pressure	44
6.7	Ductwork Layout.....	45
6.8	Good Practices.....	46
6.9	Baghouse Outlet Ductwork	47
7	CHAPTER – 7: GUIDELINES FOR YOUR FILTER MEDIA	48
7.1	Design Parameters.....	48
7.2	Fabric Types.....	49
7.3	Fabric Materials.....	50
7.4	Surface Treatment of Filtration Media.....	53
7.5	Filter (Weight/Area).....	55
8	CHAPTER – 8: GUIDELINES FOR HOPPER AND AIRLOCK	56
8.1	Hopper Design.....	56
8.2	Airlocks	57
8.3	Types of Airlocks.....	57
9	Fan Affinity Laws.....	60
9.1	Classification of Fans	61
9.2	Type of Fans.....	61
9.3	Design Parameters.....	62
9.4	Service Factors	63

9.5	Fan Location.....	64
9.6	Drive Arrangements	64
9.7	Noise.....	64
9.8	Safety and Accessories.....	65
9.9	Flow control	65
9.10	Physical Limitations.....	65
9.11	Electric motors	66
10	CHAPTER – 10: DUST COLLECTOR SAFETY.....	67
10.1	Dust Explosion	67
10.2	Technologies for Explosion Protection	67
10.3	Passive Systems.....	68
10.4	Active Systems.....	69
10.5	Other Methods of Protection	72
10.6	NFPA Codes and Standards	73

TABLE OF FIGURES AND TABLES

Figure 1.	Components of Bag Filter	7
Figure 2.	Mechanical Shaker Baghouse.....	13
Figure 3.	Reverse Air Baghouse	15
Figure 4.	Pulse Jet Filter	16
Figure 5.	Pulse Jet Cleaning.....	17
Figure 6.	Pleated Cartridge Filter Element	18
Figure 7.	Flat Cartridge Filter Element.....	18
Figure 8.	Inside Of Baghouse	24
Figure 9.	Gas Approach Velocity for Pulse Jet Baghouse.....	24
Figure 10.	Baghouse Vessel.....	26
Figure 11.	Baghouse System.....	32
Figure 12.	Dust “Pickup Points”	34
Figure 13.	Plain Opening Hood	36
Figure 14.	Flanged Hood	37
Figure 15.	Tapered Hood	37
Figure 16.	Bell Mouth Inlet Hood.....	37
Figure 17.	Tapered System	41
Figure 18.	Straight Duct System.....	41
Figure 19.	Recommended Duct Layouts	46
Figure 20.	Filter Bags	48
Figure 21.	Woven Fabric	49
Figure 22.	Dust Hopper.....	56

Figure 23.Rotary Airlock Valve	58
Figure 24.Air Moving Device.....	60
Figure 25.Dust Collecting System	63
Figure 26.Flow Control.....	65
Figure 27.Explosion Panel	68
Figure 28.Flameless Venting Device.....	69
Figure 29.Fast Acting Float Valve.....	70
Figure 30.Fire Curtain.....	71
Figure 31.Spark Detection System	72
Table 1.Synthetic Fabrics.....	11
Table 2.Recommended Conveying Velocity	42
Table 3.Recommended Material Thicknesses of Circular Ducts.....	44
Table 4.Minimum Requirements for Duct Thicknesses	44
Table 5.Fabric Materials	51
Table 6.Important Characteristics and Use of Various Fabric Materials.....	53
Table 7.Finishes for Non-Fiberglass.....	54
Table 8.Finishes for Fiberglass	54

1 CHAPTER -1: OVERVIEW OF BAGHOUSE FILTERS

A Baghouse removes dust and other particulates in airstream by forcing it through the rows of filter bags arranged in parallel. They function by lowering the velocity of dust-laden incoming air to drop out larger particles, then filtering the remaining particles by passing the air through a fabric bag. Separation happens when particles collide and adhere to the filter fabric, resulting in a layer of dust cake on the filter surface. This coating is responsible for excellent particle filtering.

The figure below shows a pulse jet bag filter, which is the most basic form of baghouse.

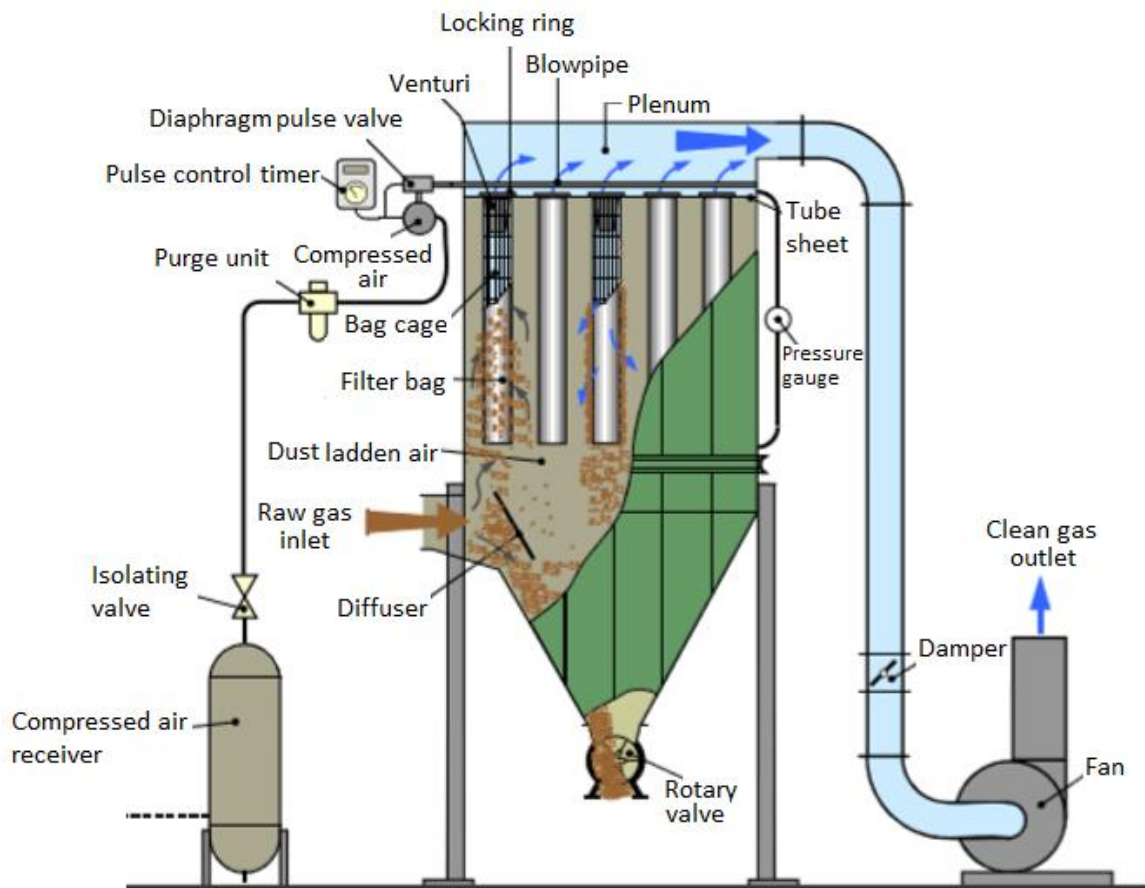

Figure 1. Components of Bag Filter

A baghouse's extended operation necessitates the removal of dust from the filter surface in a pre-determined cycle using methods such as mechanical shaking, reverse air pressure, or compressed air pulse jet. The dust eventually falls into a collection hopper beneath the bag portion, where it is expelled through an air lock valve that maintains an air seal. An induced fan propels the clean air upward from the center of the bags to the output plenum, where it is discharged into the environment.

The method by which dust is removed from the airstream differs amongst baghouses, not the way by which dust is removed from the bag. Dust-collector components vary in size, capacity,

material, and position depending on needs and usage, but they all work on the same basic principles and use comparable basic components, such as:

- a. Collection hoods to catch dust at its source
- b. Ductwork to transport the dust to a collection point
- c. Woven or non-woven filter bags to remove the dust from the air
- d. Fans and motors to generate exhaust power

The entire unit is supported from the ground on structural legs.

1.1 Design Parameters

A baghouse is sized to allow dust-laden air to travel through the filters and be cleaned without causing an excessive pressure drop. The ideal filtration velocity of the baghouse, also known as the air-to-cloth ratio, determines the amount of filter media surface area required. The average airstream velocity through the filter media is represented by this ratio of airflow rate to filter media area. The air-to-cloth ratio for a specific baghouse is determined by a variety of elements, including the dust concentration in the incoming airflow, the dust release characteristics, the porosity of the dust cake, the filter type and media surface polish, and the cleaning system type and cleaning interval.

1.1.1 Characteristics of airstream

The prominent airstream characteristics are airflow rate, temperature, and humidity.

1.1.1.1 Airflow rate

Airflow rate is used to calculate the air-to-cloth (A/C) ratio, which describes how much dirty gas flows through a given surface area of filter in a given time. It is an indicator of the filter's surface area, size and the number of bags that may be needed.

1.1.1.2 Temperature

The choice of filter media is influenced by the temperature. Teflon and fiberglass filters, for example, are recommended for high temperature applications over 400 degrees Fahrenheit, whereas polypropylene, acrylic, and polyester are not suitable.

1.1.1.3 Humidity

Humidity can cause condensation and agglomeration of the particles, necessitating the use of certain media.

Furthermore, if corrosive gases, explosive vapours, steam, or water vapours are present, the baghouse must be provided with the appropriate safety precautions.

1.1.2 Characteristics of Dust Particulates

Inlet loading, particle size distribution, and particle shape are the major items to evaluate.

1.1.2.1 Inlet Loading

The collector's inlet loading is commonly measured in grains per cubic foot of air [gr /ft³ (7000 gr. = 1 lb.)]. Dust loading can range from 2 grains per cubic foot in metalworking facilities to more than 15 grains per cubic foot in some woodworking operations. Dust concentrations in minerals processing activities can range from 0.1 to 5.0 grains/ft³. The air-to-cloth (A/C) ratio must be adjusted based on the dust loading.

1.1.2.2 Particle Size

The smaller the particle size (expressed in microns), the more efficient the collector must be. Sizes of the same particle type can vary from 0.5 to 100. Particle sizes of the same type might range from 0.5 to 100 μm . Particles that are too fine for the filter chosen may bleed through and escape the collection, causing air pollution problems.

1.1.2.3 Particle Shape

The shape or form of the particles has an impact on the media used. Spherical particles are easy to collect, while fibrous dusts clump together, necessitating the use of a coated filtration media. Dusts that are both hygroscopic and electrostatically charged create similar problems. Media must match these factors.

Abrasive, explosive, corrosive, carcinogenic, toxic, or chemically reactive dust is also a possibility. Chemical reactions, high temperature excursions, or abrasion/flex damage can cause holes and tears in the bags. The fabric's fiber material must have sufficient tensile qualities at the estimated maximum gas temperature, as well as chemical compatibility with both the gas and the collected dust.

1.1.3 Collection Efficiency

The amount of dust that should be captured by collector is determined by the dust's potential as a health hazard or public nuisance, the location of the plant, the permissible emission rate, the nature of the dust, its salvage value, and other factors.

Industry specific OSHA regulations and the EPA mandate that businesses adhere to strict indoor air quality requirements and limit dust, smoke, and fume emissions into the atmosphere.

The selection of a collector should be based on the efficiency required. Baghouses have a collection efficiency of more than 99 percent in most cases.

1.1.4 Methods of Disposal

Methods of dust removal and disposal vary with the material, plant process, volume, and type of collector used. Collectors can empty in batches or continuously. During unloading and disposal, dry materials might cause additional dust concerns.

1.1.5 Estimated Costs

Baghouses take up a lot of area to install, and the upfront costs, as well as the operating and maintenance costs, can be rather costly. Bag replacement per year can range from 25% to 50%

of the original number installed, especially if the unit is run continuously and required to meet the emission requirements of less than 0.010 gr. /cu ft. This can be very expensive if the bags are made of Teflon which are approximately \$100 for a 5-inch, 9-foot long bag.

1.2 Cleaning Mechanism

Bag filters are cleaned using either a “clean-on-time” regime or a “clean-on-demand” regime.

1.2.1 Clean-on-Time

In a clean-on-time regime, the cleaning cycle takes place at regular time intervals, independent of the dust load and pressure differentials.

1.2.2 Clean-on – Demand

In a clean-on-demand regime, the filter is cleaned when the flow resistance across the filter reaches a predetermined maximum, so the time between cleaning cycles varies, depending on the powder loading.

Clean-on-demand designs can offer lower wear and longer bag lives than clean-on-time systems in applications with fluctuating dust loadings. In industrial baghouses, a variety of cleaning mechanisms are employed. Each method has advantages and disadvantages, depending on the type of dust being collected, the temperature and composition of the gas stream, and baghouse size constraints. In the following chapter, we'll go through the most typical filter cleaning systems.

1.3 Baghouse Efficiency

Baghouses are very efficient particulate collectors. They collect particles with diameters ranging from submicron to several hundred microns with a 99 percent or better efficiency. The layer of dust on the bag, referred to as the dust cake, is principally responsible for the high efficiency, which is attained when the differential pressure between the filters is between 3 and 5 inches of water column.

The cake acts as a barrier, with tortuous pores trapping particles as they pass through. Dust concentrations in bag houses typically range from 0.5 to 10 grains per cubic foot, but in extreme circumstances, intake conditions can range from 0.05 to more than 100 grains per cubic foot (ft³).

A 99.7% efficient filter would allow no more than $(10) \times (1 - 0.997)$ or 0.03 grains/ft³ of particle concentration in the exit stream if the input dust concentration is 10 grains/ft³. A 99.9% efficient filter would only allow $(10) (1 - 0.999)$ or 0.01 grains/ft³ to pass through the outlet.

The purpose of a dust collector is to trap dust particles, not let them pass. Filter efficiency is getting increasingly regulated. The ASHRAE 52-76 test technique necessitates the following:

- a. 100% particle efficiency by weight on particles 5 micron (large particles)
- b. 100% particle efficiency by weight on particles 2 micron
- c. 99.9% particle efficiency by weight on particles 1 micron

- d. 99.8% particle efficiency by weight on particles .5 micron (very small particles)

There is no substitute for actual on-site testing if this number is critical to obtaining an air permit. Without knowing the incoming air dust concentration, the outlet dust concentration cannot be approximated with any reliable accuracy.

1.4 Standard Products

1.4.1 Common Filter Bag Diameters

- 4 to 12 inches

1.4.2 Common Bag Length or Height

- High Pressure Pulsejet; 2' up to 16' length
- Medium Pulsejet: 18' to 32' length

1.4.3 Common Filter Media

Filter bags can be produced from a variety of materials, depending on the use. Temperature and moisture levels, gas stream chemistry, dust particle qualities such as size and abrasiveness, air to cloth ratio, and mechanical parameters relating to the baghouse design must all be considered when choosing the right filter medium.

Natural fibers such as cotton and wool were used to make filters in the past. These materials are still in use, but synthetic fibers, which are more adaptable to a wider range of temperature and pH, have essentially replaced them. The following synthetic fabrics are commonly used:

Generic Name	Common or Trade Name
Natural Fiber, Cellulose	Cotton, wool
Polyolefin	Polyolefin
Polypropylene	Herculon®(Hercules); Reeveon® (Phillips)
Polyamide	Nylon®
Acrylic	Orlon ®(Dupont); Acilan® (Monsanto); Creslan®(American Cyanimid); Crylor ®(Crylor SA); Zefran ®(BASF); Draylon-T® (Bayer)
Polyester	Dacron® (duPont); Enka Polyester®(American Enka); Fortel®(Fiber Industries/Celanese); Kodel®(Eastman Chemical).
Aromatic Polyamide	Nomex® (E.I. DuPont)
Polyphenylene Sulfide	Ryton® (Phillips Petroleum)
Polyimide	P-84® (Lenzing in Austria)
Fiberglass	Fiberglass
Fluorocarbon (PTFE)	Teflon® (E.I. DuPont)

Table 1.Synthetic Fabrics

Most of these materials have good to outstanding abrasion and flex resistance. In high-temperature gas applications, fiberglass and PTFE are frequently employed.

2 CHAPTER -2: BAGHOUSE TYPES

Baghouse types are classified by their method of cleaning. The three most prominent types are:

- a. Shaker (Mechanical Cleaning)
- b. Reverse Air (Gas Cleaning)
- c. Pulse Jet (Compressed Air Cleaning)

2.1 Mechanical Shaker Baghouse

Mechanical shaker cleaning refers to the cleaning by means of mechanical shaking of bag supports. It consists of a cam mechanism positioned at the top of the unit. The filter bags are secured on the bottom and suspended from the top by a cam mechanism. Cleaning is carried out by shaking the top horizontal bar from which the bags are suspended. The shaking provides enough inertia to dislodge dust from the fabric and fall into the collecting hopper.

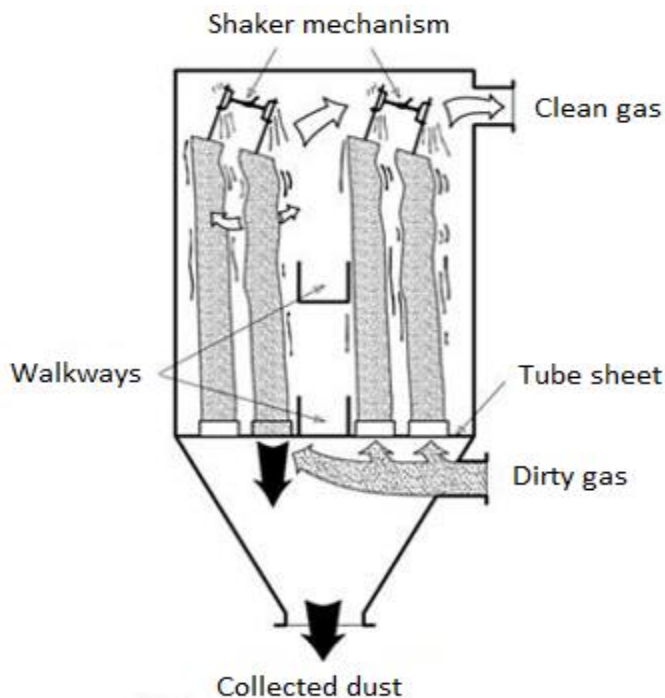

Figure 2. Mechanical Shaker Baghouse

2.1.1 Key Characteristics

- a. Dust-laden air enters the collector at the hopper and is deposited on the inside of the tubular bags.
- b. The bag is usually made of a woven material.

c. The amplitude and frequency of the shaking motion, as well as the tension in the mounted bag, are all factors that influence cleaning. The first two factors are built into the baghouse design and are difficult to modify. The following are typical values:

- About 4 Hz for frequency
- About 2 to 3 inches for amplitude (half-stroke)

2.1.2 Cleaning Operation

- a. The cleaning procedure is performed OFF-LINE. The airflow must be stopped during the shaking process in shaker baghouses, since even a tiny positive airflow might cause re-entrainment of the powder and substantially impair the cleaning efficacy.
- b. To get around this problem, baghouses are segmented so that the gas flow can be routed via the other compartments while one is being cleaned, avoiding disruptions to upstream equipment. This adds significantly to the cost of the baghouse, making it relatively expensive for applications that require continuous operation.

2.1.3 Fabric Quality

The shaker baghouse requires heavier and more durable fabric because the vigorous action of shaker systems results in excessive wear and tends to stress the bags quite severely.

2.2 Reverse Air Baghouse

In this system, the cake is removed by applying a clean air flow in the opposite direction to the filtration. The filter cake is dislodged by a combination of bag deformation and the reversed pressure differential.

The bags are held in place at the top by tension springs and feature anti-collapse rings sewed around the circle to prevent them from collapsing with the reverse flow. The length of the filter determines the number of rings required. The top of the filter is held in place by a support rack, while the bottom is connected to a cell plate.

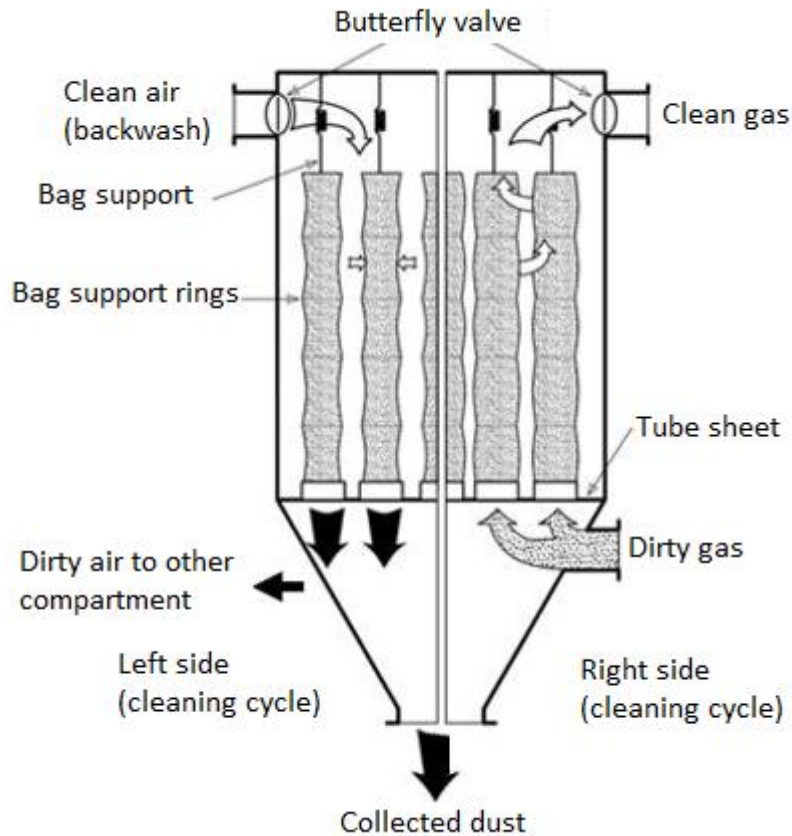

Figure 3. Reverse Air Baghouse

2.2.1 Key Characteristics

- Dust-laden air enters near the hopper and travels through a baffle, which protects the filters from abrasion and distributes the particulate more uniformly through the collector.
- They don't use compressed air; instead, they use low-pressure air with a water gauge pressure of 6 to 20 inches.
- This cleaning method is more complicated and costly than the shaker system because it requires additional fans and ducting to create the reverse flow.
- The dust cake is typically collected on the inside of the bags, as with shaker systems.
- Reverse air cleaning is a gentle procedure that results in low wear and long bag life.

2.2.2 Cleaning Operation

Bags are cleaned OFFLINE.

Because filtering must be paused during the cleaning phase, as with shaker systems, reverse air baghouses are compartmentalized to allow continuous operation.

2.2.3 Fabric Quality

Woven fabrics are typically used in reverse air baghouses. Felted fabrics are not used because

these retain dust more than woven fabrics and are thus more difficult to clean with applied pressure.

2.2.4 Precaution

To avoid excessive fiber-to-fiber and bag-to-bag contact and abrasion, a bag should be securely tied. A sagging or slack bag can result in the bag folding over the bottom and creating a pocket in which accumulated dust can rapidly abrade and tear the fabric. Excessive tensioning will stress the fabric yarns and sewing threads and prohibits movement necessary for dust cake release. To guarantee that equal and enough stress is applied to all bags, workers should utilize proper tensioning tools. The rule of thumb is 2 to 2.5 pounds per inch of filter bag circumference.

2.3 Pulse Jet Baghouse

In this system, the periodic cleaning of bags is achieved by introducing a momentary pulse of compressed air through a specially designed blow pipe, with nozzles mounted above each row of filter bags. The cleaning frequency is adjusted to maintain the proper differential pressure across the filters. When this differential pressure point is reached, a venturi device directs a high-pressure stream of clean, dry compressed air within the filter.

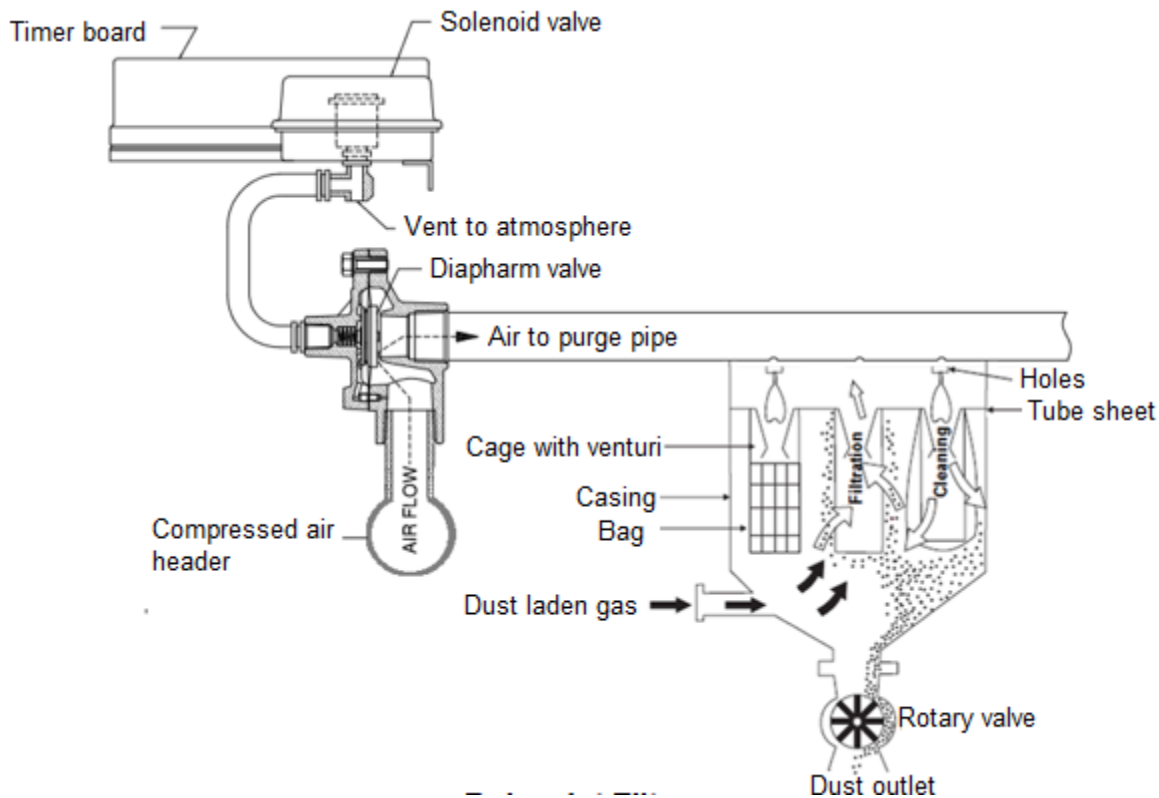

Figure 4. Pulse Jet Filter

Bags are supported by a wire cage that hangs vertically in the collector. The blast of air creates a shock wave that creates a shockwave that knocks the dust particles loose.

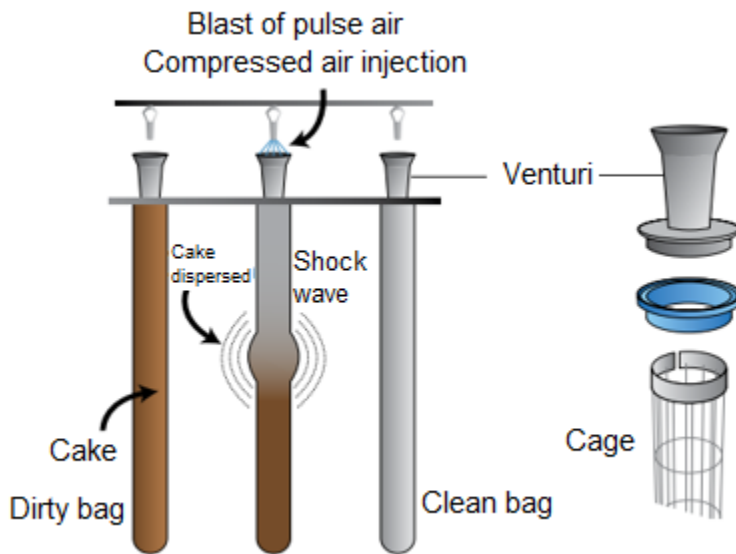

Figure 5. Pulse Jet Cleaning

2.3.1 Key Characteristics

- The contaminated air enters the housing through the hopper. Large particles immediately fall into the hopper, whereas small particles cling to the filter's outside.
- Pulse jet bag filters can be used continuously and cleaned without interrupting flow because compressed air bursts last only a fraction of a second (50 to 150 milli-second).
- The process requires 1 ft³/min (CFM) of compressed air per 1000 CFM moving gas through the dust collector.
- Traditional pulse jet baghouse uses 90 – 125 psi pressure through a venturi whereas the modern advanced systems uses 20 -40 psi without a venturi.

2.3.2 Cleaning Operation

Pulse jet collectors have the advantage of cleaning ONLINE while dust is still entering the container. The bags are cleaned one by one, while the dust laden air is filtered at the same time. A sequence controller controls the cleaning sequence automatically.

2.3.3 Performance

Pulse jet cleaning is more intense and occurs with greater frequency than the other fabric filter cleaning methods (mechanical shaker and reverse air).

2.3.4 Fabric Quality

- Usually felted (nonwoven) fabrics are used in pulse jet filters because they do not require a dust cake to achieve high collection efficiencies. However, sometimes woven bags are also used in a pulse jet filters in cases where a dust cake is desired.
- Typically bag life in a pulse jet filter is 3 to 6 years.

2.3.5 Precautions

- a. The blow pipe (compressed air manifold) holes/nozzles should be appropriately aligned above the filter bags. Rotation of the blow pipe could cause the compressed air pulse to strike the side of the bag near the top and create hole in the bag. For this reason, many times pulse jet filters are provided a mounting on the blow pipe to ensure that it can only be placed in the proper orientation.
- b. Excessive cleaning of pulse jet bags can accelerate bag wear. If there is insufficient dust cake on the bag when it is cleaned, particles or small agglomerates of particles can be dispersed.

2.4 Cartridge Filters

Cartridge filter systems are like pulse jet fabric filter systems. It uses tightly pleated filter elements rather than bags, allowing it to fit a larger quantity of filter surface area into a smaller housing. A cartridge collector with the same housing size can have up to three times the filtration area of a baghouse. 100 bags, for example, can be substituted with 36 cartridges, resulting in a significantly reduced footprint and height.

The filter media is usually a felted material composed of cellulose, polypropylene, or other flex-resistant material. The design of a cartridge filter's filter element is its distinguishing feature. To improve the filtering surface area, some cartridges have basic cylinder designs, while others have many pleats or other complex geometries.



Figure 6. Pleated Cartridge Filter Element



Figure 7. Flat Cartridge Filter Element

The cartridge collector is more efficient and requires less maintenance. A pulse-jet system is often used to clean it, which is even more effective with a cartridge collector than with a baghouse because the cartridge unit requires fewer filters.

It does, however, have some restrictions. It is quite expensive, especially in high-temperature systems, and is only advised for dry dusts.

2.5 Selection Criteria

Pulse jet baghouses and cartridge collectors are the two most prevalent air filtering technologies for industrial processes. The major benefit is that both collectors can be cleaned ONLINE.

The following criteria can be used in circumstances where the process requirements can be met using either bag or cartridge filters:

2.5.1 Application

To provide the best filtration system, you must first understand your application.

- a. A cartridge collector will perform badly if the dust particulate is sticky, tacky, or has any aggregation qualities that allow it to adhere to itself. Only dry dusts such as limestone, cement, and rock products should be filtered with cartridge filters.
- b. Cartridge filters are frequently recommended where there is high concentration of less than 1-micron ($< 1\mu\text{m}$) particulates and low moisture.
- c. Cartridge filters are not suitable for high-temperature applications over 180°F.
- d. Baghouse fabric filters are ideal for tougher applications, such as sticky or hygroscopic dusts and temperatures up to 450°F when using the right fabric, such as Teflon or fiberglass.

2.5.2 Space and Capacity

- a. Cartridge collector systems are compact compared to the baghouse systems. These can be placed close to the source of dust generation, for example, directly on storage silos, transfer points in material handling applications, and other indoor places with limited space.
- b. Cartridge collector systems do not require cages, and the cartridges can be removed from the housing externally.

2.5.3 Efficiency

Because pressure drop is generally the same across all filters, operational expenses vary little depending on the application. Bags and cartridges can both achieve capture efficiency of more than 99 percent.

2.5.4 Costs

Cartridge collectors are often more cost-effective up to 20,000 CFM, while baghouses are typically more cost-effective at higher flow rates. The life of the filter/bag and the cost of replacement filters/bags are important considerations in the life cost analysis. To make an informed selection, a life-cycle cost study is recommended.

3 CHAPTER -3: BAGHOUSE DESIGN CONSIDERAIONS

Begin your search by:

- a. Identifying the type of dust your process generates
- b. Estimating the amount of dust
- c. Estimate the size of area, the dust is collected from
- d. What type of controls needed
- e. Understand the emission regulations mandated by the environmental agency
- f. Estimating preliminary costs

3.1 Design Parameters

The key parameters related to design are:

- a. Airflow in CFM (Cubic Feet per Minute)
- b. Air Velocity in FPM
- c. Air to Cloth Ratio (or A/C)
- d. Bag spacing
- e. CAN velocity and Interstitial velocity in FPM
- f. Differential Pressure (ΔP)

Let's review **these** parameters one by one.

3.2 Airflow Rate

The amount of dust-laden air that will travel through the baghouse filter is referred to as air volume. The rate is expressed in cubic feet per minute (CFM).

You may calculate the air volume by measuring the area of the dust port in the machinery and multiplying it with air velocity of 4000 feet per minute air velocity (FPM). For example, 350CFM is required to move air at 4000 FPM through a 4" port on machinery.

- Air volume = velocity x area
- Air volume = velocity x π * diameter²/4
- Air volume = 4000 x 3.14 x (4/12)²/4
- Air volume = 350 CFM

If you have a 6" port on a machine, you will need 785 CFM.

You'll need a collection hood if you need dust removed from an open location. The air volume can be determined using the hood's opening (face area) and the velocity at which it moves.

CFM = Face velocity at hood (FPM) x Face area of hood (ft²)

FPM stands for feet per minute of air velocity in this equation. Depending on the dust characteristics, the correct CFM value should be approximately 200 FPM of face velocity

multiplied by the cross-sectional area of the hood in square feet.

To figure out how much total CFM you'll need in a facility with several dust pick-up points, add the CFM numbers from each point. Dust collectors are usually sized for this value.

3.3 Air Velocity

There are 4 terms used to describe air velocities in baghouse dust collectors:

1. **Conveying velocity:** velocity of air through the ductwork.
2. **Filtration velocity:** velocity of air across the filter cloth area. It is also related to the air to cloth ratio (A/C) of the baghouse.
3. **Interstitial velocity:** refers to the upward velocity through the baghouse space between the filter bags.
4. **Can velocity:** refers to the upward velocity through the entire housing of the baghouse without taking into consideration the cross-sectional area taken up by the filter bags.

Let's discuss these terms in detail.

3.3.1 Conveying Air Velocity

The velocity of air in a ductwork is known as conveying velocity. It is computed as:

$$\text{Conveying air velocity (ft/min)} = \frac{\text{Airflow (ft}^3\text{/min)}}{\text{Cross sectional of duct (ft}^2\text{)}}$$

The system must be carefully engineered to keep the transported material suspended, usually between 3500 and 4000 feet per minute (FPM).

- a. Ducts with velocities higher than 4000 FPM can lead faster wear and tear by means of abrasion (especially abrasive dusts like metals, ceramics, etc.). Furthermore, too high velocity might cause valuable product to be pulled out of the process and into the waste stream.
- b. Ducts having a velocity less than 3500 FPM may allow material to settle out, resulting in dust build-up in the duct. These dust accumulations in the ducting can pose serious safety risks and can trigger fire or explosion.

3.3.2 Filtration Air Velocity

The filtration velocity, also expressed by term the "Air-to-cloth ratio" or A/C ratio, is the most important size parameter for a baghouse system. It describes how much air is filtered in relation to how much filtering medium is used. Mathematically:

$$\text{Air to cloth ratio} = \frac{Q}{A}$$

Where

- Q = volume of air in ft³/min
- A = area of the filter cloth in ft²

This ratio is usually expressed as ft³/min/ft² of bag area [or CFM/ft² of cloth area]. For example:

- a. The air-to-cloth ratio of a dust collector with 4,000 CFM of airflow and 2,000 ft² of filter material is 2:1.
- b. The air-to-cloth ratio of a dust collector with 2,000 CFM of airflow and 2,000 ft² of filter material is 1:1.
- c. The air-to-cloth ratio of a dust collector with 1,000 CFM of airflow and 2,000 ft² of filter material is 1:2.

3.3.2.1 Why Important?

- a. Higher A/C ratio means:
 - Lesser filter media – i.e. more volume of air passes through the fabric area.
 - Baghouse will use less fabric, therefore less capital cost. However, lesser filter media can have serious adverse impacts - High pressure drop, rapid filter clogging, reduced collection efficiency, blinding, reduced filter life and frequent maintenance and workers exposure. Maintenance costs will be high and will soon outweigh all capital savings realized by using less filter material.
- b. A lower A/C ratio means:
 - More filter media – i.e. lesser volume of air through the fabric area.
 - Baghouse will use more fabric; therefore, compartment size will increase and therefore incur higher capital costs. However, performance will increase, and money will be saved through reduced maintenance and labor time spent replacing bags.

3.4 Typical Air to Cloth (A/C) Ratios

Air to cloth ratio for a given application depends on the type and size of the dust particles, particle size distribution, fabric characteristics, particulate matter loadings, and the performance requirements. Here are a few guidelines:

- a. Air to cloth ratios below 4:1 are considered low and while those above 7:1 are considered high. Moderate ratios range from 4:1 to 7:1. Depending primarily upon dust particle size, a good choice of A/C ratio is usually in the range of 4:1 to 6:1
- b. Applications that produce a large volume of particulates will require more filter media than applications that produce a smaller volume of particulates. Source capture systems will usually require a lower air-to-cloth ratio than ambient systems because particulates are more concentrated.
- c. Applications producing fine particulates shall have an A/C ratio of 2:1 to 5:1. (felted fabrics).
- d. Application producing coarser or granular particulates shall have an A/C ratio of 8:1 to 10:1 (felted fabrics).
*Typical values of air to cloth ratio for woven fabrics are about half the values for felted fabric because the free area available for gas flow is much less.
- e. Applications where the clean air discharge limit is critical, say, no more than 5 mg/Nm³ of particles, often have A/C ratios of 3:1 to 4:1, but less stringent, easier applications may have A/C ratios up to 6:1.
- f. Mechanical shaker collectors are typically designed for the A/C ratio of 2:1 to 6:1.
- g. Reverse air collectors generally have very low A/C ratios of 1:1 to 4:1.
- h. Pulse jet baghouses are designed for A/C ratio of 2:1 to 10:1. These units typically use felted fabrics as bag material.

The A/C ratios of reverse-air fabric filters are the lowest, hence more cloth is required for a given flow rate. These tend to be larger in size.

Pulse-jet baghouses have the largest A/C ratio; hence they are often smaller.

Note: At the end of this course, Annexure 1 lists typical suggested A/C ratios for baghouses used in industrial processes. Use these values as a guide only. If the dust loading is excessive or the particle size is small, the actual design values may need to be reduced.

3.4.1 Calculations

Air to cloth (A/C) ratio is calculated as follows.

The bag areas for cylindrical pulse jet bags and reverse air bags are calculated based on the formula:

$$A = \pi D h N$$

Where,

- $\pi = \text{pi}, 3.14$
- $h = \text{bag height in feet}$
- $D = \text{bag diameter in feet}$
- $N = \text{Number of bags}$

The formula is for the area of the side of a cylinder. In using this equation, it is assumed that filtration occurs only on the side of the bag, not on the circular top (reverse air) or bottom (pulse jet). This is a reasonable approach because both types of bags usually have a solid cup across the circular area.

3.4.1.1 Example

Calculate the gross A/C ratio for a pulse jet baghouse equipped with 1800 bags, a bag length of 20 ft, and a bag diameter of 10 inches. Use an actual gas flow rate of 1, 20,000 ft³/min.

Solution:

$$\text{Bag area} = \pi D h$$

$$\text{Bag area} = 3.14 \times (10/12 \text{ inches/ft}) \times 20 \text{ ft}$$

$$\text{Bag area} = 52.33 \text{ ft}^2/\text{bag}$$

The gross air-to-cloth ratio is calculated assuming that all the bags are in service.

$$\text{Total number of bags} = 1800 \text{ bags}$$

$$\text{Total fabric area} = 1800 \times 52.33 = 94,194 \text{ ft}^2$$

$$\text{A/C gross} = 1, 20,000 \text{ ft}^3/\text{min}/94,194 \text{ ft}^2$$

$$\text{A/C gross} = 1.27 \text{ (ft}^3/\text{min)/ft}^2$$

3.5 Bag Spacing

Bag spacing is critical for efficient operation and maintenance. It requires knowing the internal velocities in the baghouse. There are two terms for the measured velocity inside a baghouse: Interstitial velocity and Can velocity.

3.5.1 Can Velocity

“Can velocity” is the upward air velocity in the baghouse’s chamber below the bottom of the filters and is calculated by dividing the airflow rate by the chamber’s cross-sectional area.

3.5.2 Interstitial velocity

Interstitial velocity is the airflow’s upward velocity between the bag filters and is determined by dividing the volume of dust-laden air entering the baghouse by the net flow area available in the airflow’s direction. The net flow area is determined by subtracting the total axial cross-sectional area of all bag filters from the baghouse chamber’s total cross-sectional area.

3.5.3 Why Internal Velocities are Important?

The dust generated during filter cleaning will stay in suspension and not fall into the hopper if either the “Can” velocity or the “Interstitial” velocity in the baghouse is too high. If the dust remains suspended, it will gravitate to the filters, eventually penetrating and blinding them, causing a high differential upset condition, which can only be corrected by changing the filters.



Figure 8. Inside Of Baghouse

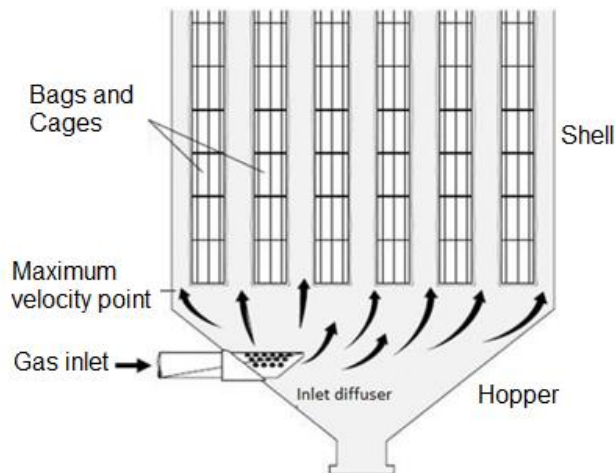

Figure 9. Gas Approach Velocity for Pulse Jet Baghouse

The area around the bottoms of the bags is the place of highest velocity in pulse jet units, as indicated in the figure above. All the particulate laden gas to be filtered by the bags must pass through this area to reach the bag surfaces. If the upward velocity of the gas stream exceeds the downward terminal settling velocity, the particles will be captured and returned to the bag-dust cake surface. Therefore, it is important to be sure your interstitial velocity is at or below an acceptable optimal level.

3.5.4 What is Optimal Interstitial Velocity?

Interstitial velocity of less than 400 FPM is recommended. Bulk density, particle size distribution, agglomerating/non-agglomerating tendencies of the dust, and inlet loadings all play a role in determining the appropriate interstitial velocity.

3.5.4.1 Bulk Density

The higher the bulk density of a dust, the greater its tendency to settle downward against the rising air. Therefore, higher interstitial velocities may be used for higher bulk density dusts.

3.5.4.2 Particle Size

The smaller the particle, the slower it settles or falls, and the greater the effects of upward air flow keeping the dust in suspension. Generally, smaller particle sizes should indicate the use of lower interstitial velocities.

3.5.4.3 Agglomerating/non-agglomerating

Material that tends to agglomerate (stick together) generally will be pulsed off more in “mass” than in discrete particles. Agglomerating particles may allow for the use of higher interstitial velocities.

3.5.4.4 Inlet Loading

Inlet loading is the rate of the mass of solid material being introduced into the dust collector. Extremes of high and low loadings might allow slightly higher interstitial velocities.

3.5.5 How to Optimize Interstitial Velocity

Bag spacing determines interstitial velocity. Units that crowd the bags close together have high interstitial velocities because there is very little area between the bags for the inlet gas to pass through.

To reduce interstitial velocity, it is normally desirable to separate the bags far apart, such as by increasing the spacing between rows of bags from the standard of 8” centres to something greater. Keep in mind that not only the row to row spacing, but also the space between the bags in the row, should be considered. Refer to the scenarios below.

3.5.5.1 Changing the length of the filter bags

Resize the dust collector using 8 ft. bags instead of 10 ft. bags or change from 8 ft. to 6 ft., etc.

3.5.5.2 Change the diameter of the bags

Use a 4-1/2” dia. bag instead of a 5-3/4” dia. bag to make a dramatic reduction in interstitial velocity. Bag-to-bag spacing increases from 2” to 3-1/2”.

However, this approach has drawbacks. Practically all modern process baghouses use what is known as long bag technology; with filter bag lengths up to 30 ft. Long filter bags have greater filter area, meaning that fewer bags are required. This reduces the size of the baghouse casing, as well as associated costs and the baghouse's footprint. But their resulting interstitial (rising) velocities would limit their capacity. To solve this problem, a better solution is to use high entry inlet.

3.5.5.3 Use a high inlet

A percentage of the incoming flow can be introduced laterally into the array of filter bags, directly into the upper portion of housing instead of the hopper. This greatly reduces the vertical velocity component and protects against re-entrainment of the particulate.

You can **use a combination** of above strategies to achieve the desired results.

3.6 CAN Velocity

Sometimes the term “CAN velocity” also called “Approach Velocity” is commonly confused with interstitial velocity, and with good reason. These are practically the same when the filter bags extend down to the hopper level.

Can velocity is the vertical flow velocity above the hopper level, but before reaching the bottom of the bags, while interstitial velocity is the vertical flow velocity once the flow is past the bottom of the filter bags. Interstitial velocity is obviously higher due to a much smaller cross-sectional area once the filter bags are considered.

3.6.1 How to optimize Can Velocity?

The presence of dead space beneath the bag array results in a low CAN velocity, essentially creating an internal dropout chamber that helps distribute and minimise horizontal flows that might cause abrasion at the bottom of the bags. Experience shows that baghouses with bags some distance away from the hopper have extended filter bag life, and the calculations show that creating this low velocity zone is feasible and beneficial.

3.6.1.1 Example

A baghouse is designed for 3000 CFM airflow and has a round inlet duct of 12 inches diameter. The baghouse vessel is 40 inches x 40 inches and it contains 25 bags of 6 inches diameter and 120 inches height. Calculate the conveying velocity, interstitial velocity, can velocity and filtration velocity.

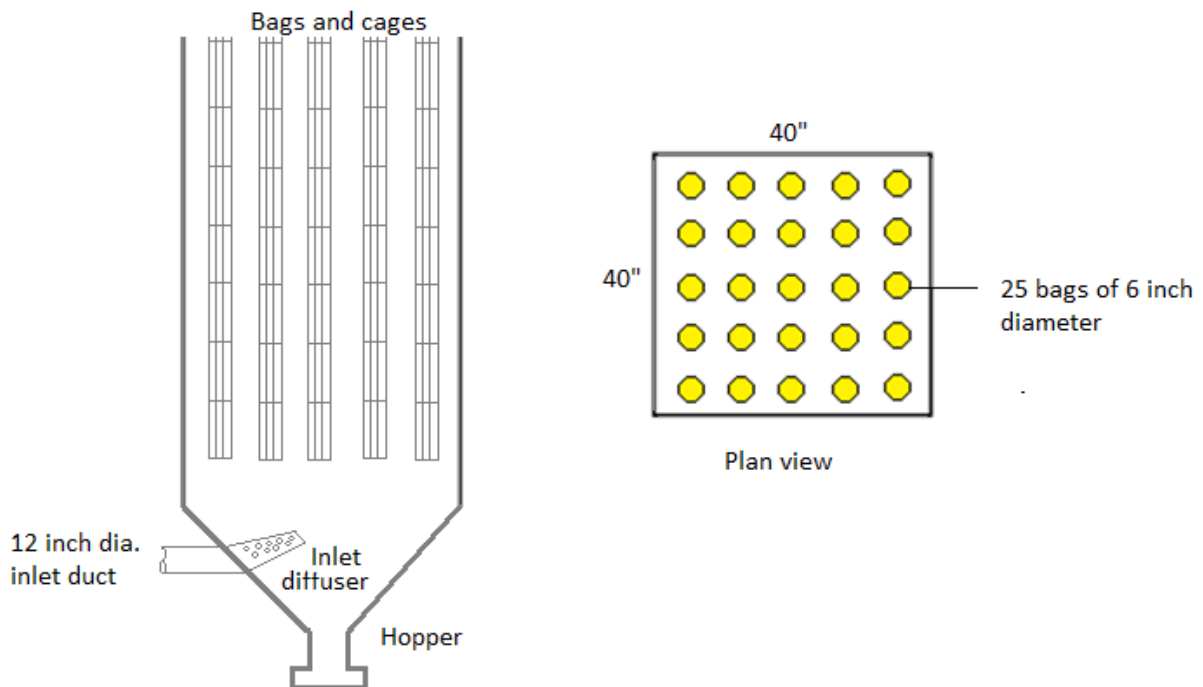

Figure 10. Baghouse Vessel

Solution

Inlet Velocity

$$\text{FPM} = \text{CFM} \div \text{Cross sectional of duct}$$

Inlet duct (round) = 12-inch diameter = 1 ft. diameter

Area of duct = $\pi * \text{diameter}^2 / 4$

Area = $(3.14 \times 1 \times 1) / 4 = 0.8 \text{ ft}^2$

Inlet Velocity = $3000 \text{ CFM} / 0.8 \text{ ft}^2 = 3750 \text{ FPM}$

Filtration Velocity

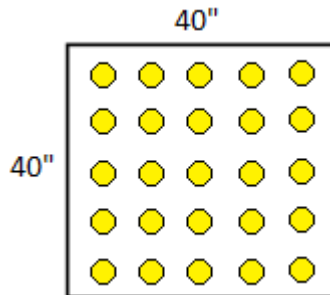

Bag Area is calculated using the circumference of the bag times the height.

Bag Area = Number of bags * $\pi * \text{diameter} * \text{height}$

Bag diameter = 6 inches = 0.5 ft.

Bag length = 120 inches = 10 ft.

Bag Area = $25 * 3.14 * 0.5 \text{ ft} * 10 \text{ ft} = 393 \text{ ft}^2$

Filtration Velocity = $3000 \text{ CFM} / 393 \text{ ft}^2 = 7.6 \text{ FPM}$

Note this also signifies gross A/C ratio = $7.6 \text{ (ft}^3/\text{min)}/\text{ft}^2$

Can Velocity

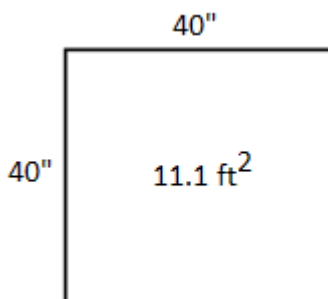

Vessel area = Length x Width

Length = 40 inches = 3.3 ft.

Width = 40 inches = 3.3 ft.

Area = $3.3 \times 3.3 = 11.1 \text{ ft}^2$

Can Velocity = $3000 \text{ CFM} / 11.1 \text{ ft}^2 = 270 \text{ FPM}$

Interstitial Velocity

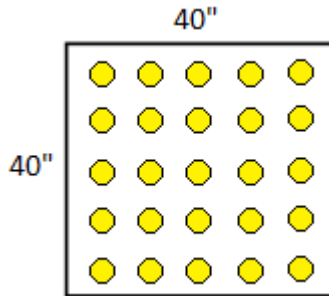

Number of bags = 25

Bag diameter = 6 inches or 0.5 ft.

Bag height = 120 inches or 10 ft.

Bag bottom area = Number of bags * π *diameter²/4

Bag bottom area = 25 * 3.14 * (0.5)² / 4 = 4.9 ft²

Interstitial area = 11.1 - 4.9 ft² = 6.2 ft²

Interstitial velocity = 3000 CFM / 6.2 ft² = 480 FPM

Interstitial velocity = 1.8x Can Velocity

Summary Velocities

- Inlet Velocity 3750 FPM
- Filtration Velocity 7.6 FPM
- Can Velocity 270 FPM
- Interstitial Velocity 480 FPM

3.7 Baghouse Compartment Design

The compartment design should allow for proper inspection, cleaning, and replacement of bags. For example:

- a. In a reverse-air unit, there should be enough space between bags for maintenance staff to visually inspect each bag for holes or broken bags. The bag can be replaced, or a cap can be placed over the tube sheet opening to keep the bag sealed until it is changed later.
 - The bag layout should allow the maintenance technician to reach all the bags from the walkway. One measure of bag accessibility is called bag reach and is the maximum number of rows from the nearest walkway. Bag reach does not have a specific number; however, most units have a value of 3 or 4.
 - Very tall bags are often difficult to install when there is limited overhead clearance to remove the failed bag mounted on the rigid cage. Failed bags can partially fill with solids in some instances, and the weight can be significant in the case of tall bags. For all these reasons, short bags (8 to 14 feet) are preferred over tall bags.
- b. Bag spacing is critical in pulse-jet baghouses to avoid bag abrasion. Bag-to-bag abrasion can occur at the bottoms of the bags since they are only fastened to the tube sheet at one end, allowing them to hang freely. Bags that rub together due to slight bends in the bag support cages or slight warping in the tube sheet or excessively long bags might cause wear. The optimal bag size must therefore reflect a balance between these factors.

3.8 Baghouse Pressure Drop (ΔP)

One of the most significant elements to consider in baghouse design is the pressure drop, often known as differential pressure (P), between the clean and dirty gas sides of the baghouse. Pressure drop through a baghouse is caused due to the air flow's resistance when air passes through the filtering bag and the filter cake. The pressure drop is usually measured in inches of water (in-WC).

Baghouse collectors are generally designed and sized to operate with a differential pressure between 3 and 5-inches WC.

A differential pressure gauge (Magnehelic® gauge) or a manometer can readily measure the pressure drop across the bags. A newly installed baghouse will have a pressure drop of only 0.5 to 1.5 inches of WC. In operation, this pressure differential will gradually increase and provide the best efficiency between 3 and 5-inches WC. This pressure differential will not be able to rise much higher than this with a well working self-cleaning baghouse. A pressure reduction of more than 5 inches WC usually means the bags have been blinded by particles. This happens when dust particles have saturated every microscopic void between the bag fibres to the point that airflow is significantly restricted.

Pressure differentials in the baghouse aren't always a good indicator of filter efficiency. The formation of a dust cake on the bags' outside surface may actually improve efficiency, but a layer that is too thick would reduce the bags' ability to handle the intended amount of air.

3.8.1 Why differential pressure is Important?

Controlling the differential pressure (DP) in your baghouse is essential for getting the most out of your system's performance and efficiency. High DP means the system fan needs to work harder to pull the same amount of airflow throughout the system. This will result in much higher energy costs to run the system fan at high speeds and may cause premature fan/motor failure if overworked.

If DP starts to rise above the recommended levels, the system will suffer a loss of suction at the pickup (collection) points (creating inadequate venting) and the air speed in the ductwork will drop. This will mean less performance from your system and product dropout, especially so for certain industries that are more dependent on the dust collection system as part of the process such as cement, powdered metals, chemical processing, etc.

OSHA requires that fabric dust filter collectors, which are a part of a pneumatic dust collection system, be equipped with a monitoring device that will indicate a pressure drop across the surface of the filter.

3.9 Controls and Instrumentation

Federal and state environmental regulations require industrial facilities to install dust collection systems to control particulate emissions and prepare a Compliance Assurance Monitoring (CAM) plan. This is because simply installing a dust collector does not guarantee that it will capture a sufficient percentage of dust emissions. Controls and instrumentation are required for emission monitoring and recording dust loadings on a timed basis.

The following are some of the different types of emissions monitoring methods:

3.9.1 Visual Observations

Visual inspection of the stack to determine the level of visible emissions is the most basic kind of monitoring. This basically implies that someone examines the stack or collector outlet to see if anything is coming out of it. Visual observations are largely limited to sites that aren't considered "major sources" or are subject to more stringent EPA regulations. Nevertheless, visual observation still serves well as a backup monitoring method, should a primary system fail.

3.9.2 Differential Pressure

Differential pressure (DP) with reference to dust collector refers to the amount of pressure loss due to an air stream passing through the fabric filters. Resistance increases as the filters become dirty and more loaded with collected dust. Eventually, when the filters become worn out and the dust begins to seep deeper into the filter fibres, the filter becomes harder to clean and thus the resistance increases, causing the differential pressure to rise in the dust collector.

The DP on the dust collector is often used as a substitute for direct particle concentration readings. Although indicative of a problem (rather than a direct emissions measure), a DP reading outside of normal ranges often indicates a baghouse operational issue (for example, blinded or perforated bags).

3.9.3 Opacity Monitoring

Opacity monitors are vastly superior in detection accuracy and reliability. They work by bouncing a beam of light between two mirrors located on opposite sides of an exhaust outlet, i.e. stack. The meter then measures how much the light beam is weakened with each pass through the gas, thus directly measuring the opacity level of the plume. Additionally, opacity monitors provide a continuous signal output that can be connected directly to a plant's distributed control system (DCS) or programmable logic controller (PLC) system for more effective remote monitoring and logging of emissions data for later analysis.

3.9.4 Triboelectric Detection

In a Triboelectric system, an electrically isolated metal probe is inserted into the air stream (i.e. stack), and a tiny current (pico amps) is generated when the dust particles pass nearby the probe (AC signal) or when they collide with the probe (DC signal). An increase in the instrument signal provides a qualitative indication of increased emissions. The two main advantages of triboelectric detection are its sensitivity and low maintenance requirements.

Triboelectric detectors are the most accurate particle concentration measurement devices used for emissions today. They can detect concentrations down to 0.005 mg/m³, substantially more sensitive than opacity meters. This level of sensitivity means triboelectric detectors are frequently used in plants with very strict emissions limits, such as those dealing with hazardous compounds or with high combustibility. Additionally, many facilities with air permits that require fabric filter dust collector operators to carefully monitor for broken filters make use of triboelectric detectors, or bag leak detection systems due to their ability to detect bag failure in its earliest stages.

In continuous monitoring systems, these monitors are generally equipped with circuits for audio alarms or visual light indicators to alert operators to upset conditions. These monitors have also been used to trigger devices, such as abort gates, when particulate levels increase dramatically or during smoky conditions generated by a smouldering fire on a filter.

These instruments are designed and installed in accordance with U.S. EPA Performance Specification 1 (40 CFR Part 60, Appendix A).

4 CHAPTER - 4: BAGHOUSE COMPONENTS

The Baghouse system consists of Five (5) main components:

1. Dust collection hood
2. Inlet and outlet ductwork
3. Filter media
4. Collection hopper & Airlock
5. Fan

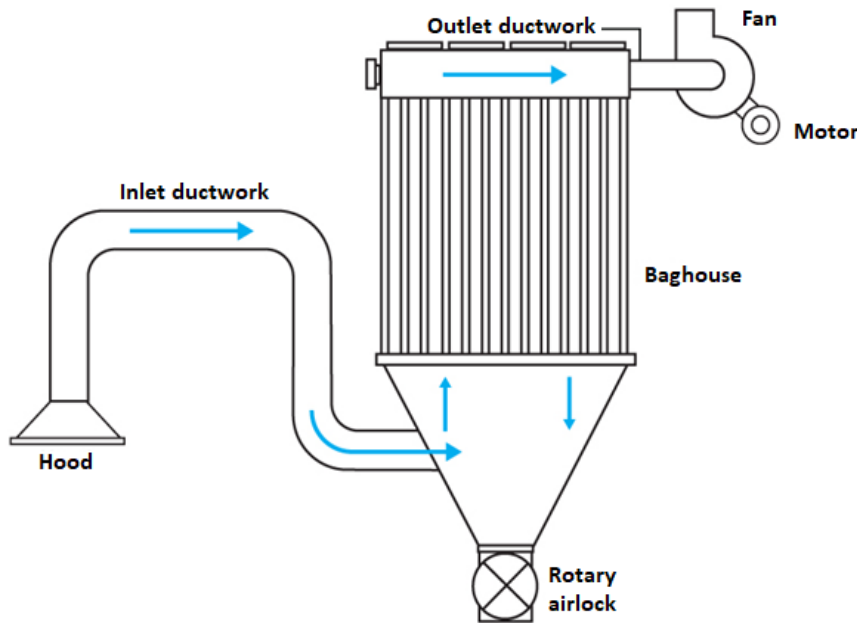

Figure 11. Baghouse System

4.1 Collection Hood

Dust collecting hoods are used to collect dust. A shroud around a saw or grinder, a fume hood over a workstation, a bell mouth hood over a pile of dust, or a full painting booth are all examples. The “pick-up” end of the system must be carefully designed to meet the needs of the problem and to minimize the power, airflow, and pressure requirements to be imposed on the dust collector design.

The velocity at the opening of the hood (the face velocity) must be sufficient to sustain the capture velocity despite disruptive air motions, which is the most critical part of hood design. The air velocity must be sufficient to carry the dust from the point of emission into the hood. Other design factors include the hood's shape, size, position, and air flow rate through the hood.

4.2 Ductwork

Ductwork transports impurities from sources to the baghouse and exhausts clean air to the atmosphere. These can range in size from 1-1/4 inches in diameter (for a hand-held tool) to 12 inches in diameter (for a medium-sized dust collection system with a 4000 CFM capacity).

The air velocity in the ductwork should be high enough to prevent the particles from settling. Ductwork should be composed of a sturdy, well-supported material that can withstand wear and

tear, especially when handling abrasive dusts. For ducting design, SMACNA codes should be used.

4.3 Filter Medium

The purpose of filter is to separate dust from gas. The filter medium consists of the fabric bags and their support structure. Most filter designs use felted fabric or woven materials. Filter bags may be supported at the top and bottom or by internal cages. Particles are either collected on the inside or the outside of the filter bags depending on the individual baghouse design.

4.4 Collection Hopper

Collection hopper is used to temporarily store the collected dust that is dislodged from the filter bags by the cleaning mechanism processes. The hopper may be designed to include strike plates, rappers, and/or vibrating mechanisms to assist in dislodging caked dust inside the hopper.

4.5 Discharge Device

A discharge device is located at the bottom of a hopper that facilitates the emptying of the collection hopper. Most industrial baghouses utilize automatic, continuous discharge devices such as double dump devices, rotary airlock valves, screws, slide gates, hinged doors, and drawers.

4.6 Fan

The motive energy for moving polluted air from the dust-producing source to the dust collection is provided by the fan. Between the baghouse and the exhaust stack, the fan is usually the last section of the filtering system. This configuration allows practically the whole system to be kept under negative pressure in relation to the workplace, ensuring that air will not leak anywhere in the system.

The fan is designed to suck a certain volume of air (measured in CFM or Cubic Feet per Minute), with a certain pressure/airflow curve. Dust collectors operate in the medium pressure range (5-20 inches water gauge pressure). The fan systems are designed for continuous duty applications.

Each component is critical to the system's proper operation. If any of these components is neglected or applied incorrectly, the entire system will fail to deliver the expected performance. In the following chapters, we'll go over some basic design suggestions and guidelines for these components.

5 CHAPTER -5: GUIDELINES FOR YOUR COLLECTION HOODS

Dust collecting hoods are used to collect dust.

5.1 Design Objective

A dust collection hood is specifically designed to accomplish the following:

- a. Contain the dust – limit the volume of space where the dust can go.
- b. Capture the dust – direct the air flow through the hood's face.
- c. Convey the dust – transport the dust to the dust collector via ductwork.

Hoods can be an integral part of the process equipment or can consist of a simple, stationary plenum mounted above or to the side of the source, a large moveable plenum, or the process equipment itself.

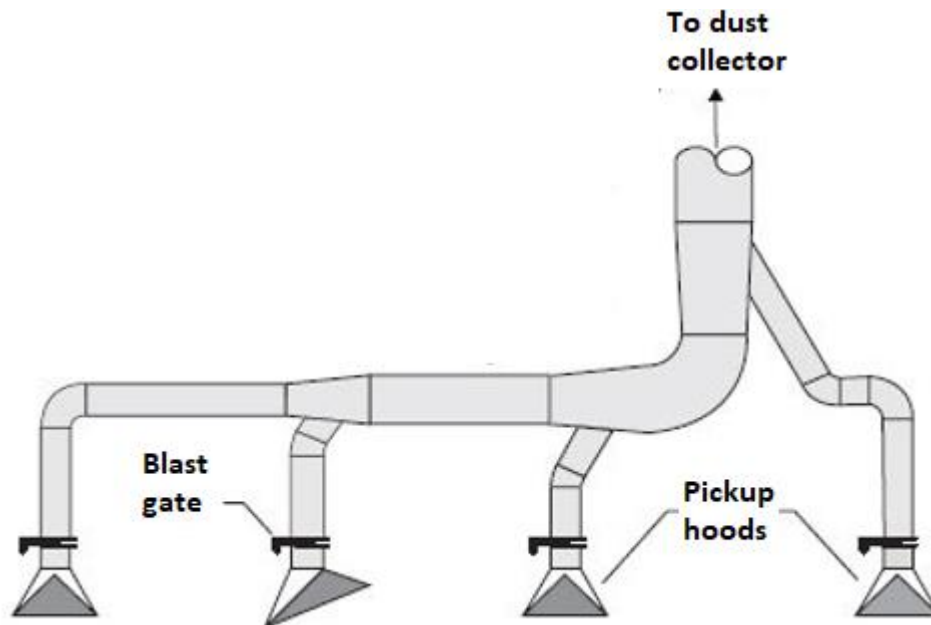

Figure 12. Dust "Pickup Points"

The figure above shows schematic of multiple hoods—also called dust “pickup points” that are located close to the dust generation point and connected to the dust collector. Blast gate is provided at each branch to maintain system pressure ensuring that the velocity at each hood is high enough to collect the dust and keep it aloft in the ducts.

5.2 Effectiveness of the Hood System

The effectiveness of the complete system to capture dust from the air is greatly influenced by the design of dust collection hoods. If hoods do not trap pollutants effectively, they scatter directly into the plant air and eventually flow through the atmosphere.

Here, you need to understand three terms: (1) Fugitive emissions (2) Emissions captured by hood and (3) Stack emissions.

5.2.1 Fugitive Emissions

The fugitive emissions are the emissions that escape capture by hoods.

Fugitive emissions = Total emissions - Emissions captured by hood

5.2.2 Captured Emissions

The captured emission is the difference between the total emissions and the fugitive emissions.

Emissions captured by hood = Total emissions – Fugitive emissions

It is usually described by term hood capturing efficiency, and is:

Efficiency = (Emissions captured by hood / Total emissions) x 100%

5.2.3 Stack Emissions

Stack emission is dependent on the dust collector efficiency and is given as:

$$\text{Stack emissions} = \frac{100\% - \eta}{\text{captured emissions}}$$

Where:

η = Baghouse collection efficiency (%)

5.2.3.1 Example:

The capture efficiency of the hood is 92 percent, and the collection efficiency of the baghouse filtration is 95 percent. Calculate the fugitive and stack emissions if the process served by this system produces 140 pounds of pollutant per hour.

Solution:

Fugitive emissions = [(100% – 92%) x (140 lbm/hr) = 11.2 lbm/hr

Captured emissions = 140 lbm/hr - 11.20 lbm/hr = 128.8 lbm/hr

Stack emissions = [(100% - 95%) x (128.80 lbm/hr) = 6.4 lbm/hr

See that fugitive emissions are more than stack emissions.

As you can see that the fugitive emissions are more than the stack emissions. What this means is that if the hood is not good in capturing dust, the dust particulates will still float around in the work area.

5.3 System Design

The most important parameters in the design of an exhaust hood are:

- a. Capture velocity
- b. The inlet opening and shape of the hood
- c. The rate of airflow through the hood
- d. The positioning of the hood
- e. Static pressure

5.4 Capture Velocity

Capture velocity is the air speed at any point in front of the hood or at the hood opening necessary to overcome opposing air currents and to capture the dust laden air at that point by causing it to flow into the hood.

An efficient collection hood should have a flow pattern and capture velocity sufficient to control dusting without collecting excessive dust. For most applications, the capture velocity at the hood's face is between 200 and 250 FPM.

- a. If the capture velocity is insufficiently low, the dust particles won't be sucked by the system.
- b. If the capture velocity is too high, excessive particulate will be introduced into the hood, ductwork and eventually to the dust collector. The filters inside the dust collector will be subjected to a higher-than-design dust load. As a result, the dust collector operates at a larger differential pressure than anticipated, necessitating more frequent filter cleaning. In these situations, the filters wear out faster and require more cleaning energy. The remedy to this problem is to ensure that all collecting hoods are appropriately designed and positioned, and that the space surrounding the collection hood is as enclosed as possible to avoid excessive outside air from being drawn into the system.

5.5 Rate of Airflow

The rate of airflow through the hood is the most important parameter. Airflow is also affected by the shape of the hood discussed below.

5.6 Hood Opening and Shapes

There are four basic hood designs listed below in order of increasing effectiveness, but also in their increasing fabrication cost.

- a. Plain opening hood
- b. Flanged hood
- c. Tapered hood
- d. Bell mouth inlet hood

5.6.1 Plain Opening Hood

The plain hood represents the most common and least expensive of all hood configurations. It is just an open duct which terminates near the dust generation point.

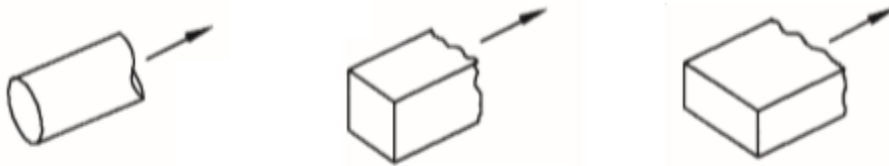

Figure 13. Plain Opening Hood

This hood configuration pulls air not only from in front of the duct opening, but, unfortunately, also from behind the hood opening, which makes it inefficient. This configuration also creates a high degree of turbulence that can contribute to increased energy losses and a potentially bigger fan. This hood configuration option is less than optimal from a total cost of operation perspective.

5.6.2 Flanged Hood

The flanged hood is a simple design with a low fabrication cost, and it improves on the plain hood design by adding a flange.

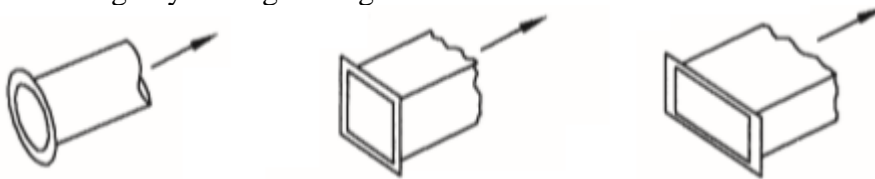

Figure 14. Flanged Hood

The flanged hood provides better performance because the air/energy used to collect the dust is limited to the zone in front of the open duct. Excess turbulence may however still be present with flanged hoods.

5.6.3 Tapered Hood

A tapered hood allows air to enter the hood slowly than a plain or flanged entry, reducing turbulence in the duct at the back of the hood.



Figure 15. Tapered Hood

This more gradual transition saves energy and lowers the fan's running expenses, resulting in long term savings for a minor increase in hood fabrication costs.

5.6.4 Bell mouth Inlet Hood

In terms of performance, the bell mouth hood is the best. It combines the advantages of flanged hoods with a smooth transition from flange to duct entry. This smooth transition minimizes turbulence as air enters the duct.

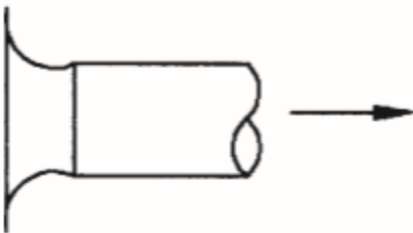

Figure 16. Bell Mouth Inlet Hood

It is the most effective external hood design available since it combines the airflow reduction performance of a flange with the minimal turbulence of the spun bowl entry profile. Of course, improved performance does not come without a financial investment; the costs are higher. However, when you evaluate the plant cleanliness, smaller ducts, smaller collectors, and smaller fans yielding lower air volumes, the initial expenditures may be soon covered.

5.7 Hood Position

As far as feasible, the hood should enclose the operation. If enclosure is not possible, the hood should be placed as close to the source as possible and shaped to control the contamination area. If the dust generated is 12 inches from the hood opening, a volume of 1000 CFM might be required. But, if the hood opening is 24 inches away, the required CFM volume increases as the **square of the distance** to 4,000 CFM.

To estimate the required air volume to produce that velocity, we use the equation from the Industrial Ventilation Manual.

$$Q = (10X^2 + A) V$$

Where,

- Q = Total airflow required in CFM
- X = Distance away from the source in ft
- A = The cross-sectional area of the duct in ft²
- V = Capture velocity in FPM

In the example above, you may notice that the volumetric flow rate requirements increased approximately four times when the distance between the hood and the contaminant source is doubled.

5.8 Hood Entry Loss and Static Pressure

Hood entry loss is the loss of pressure caused by airflow moving into the hood.

The hood static pressure is simply the static pressure in the duct immediately downstream from the hood. This static pressure is entirely dependent on the hood geometry and the gas flow rate. The hood static pressure is determined by:

- a. The velocity pressure in the duct from the hood
- b. The hood entry loss

Mathematically:

$$SPh = - (VP + He)$$

Where:

- SPh = hood static pressure (in. W.C.)
- VP = duct velocity pressure (in. W.C.)
- He = Hood entry loss (in. W.C)

The velocity pressure, VP is given by:

$$VP = \left(\frac{V}{4005} \right)^2$$

The velocity, V is given by:

$$V = \frac{Q}{A}$$

Where:

- V = duct conveying velocity in (ft/min)
- Q = volumetric gas flow rate (ft³/min)
- A = cross-sectional area of duct or equipment (ft²)

The hood entry loss is given by:

$$H_e = F_h \times VP$$

Where

- F_h = hood entry loss coefficient (dimensionless). F_h for different hood opening is as below:
 - Plain hood opening = 0.93
 - Flanged hood opening = 0.49
 - Tapered hood opening = 0.25
 - Bell mouth inlet opening = 0.04 (most efficient)

It is important that the pressure losses are a minimum, so that the total flow can be provided by a smaller fan.

5.8.1 Example

Calculate the hood static pressure, if the hood coefficient of entry is 0.49, and the gas flow rate through an 18-inch (1.5 ft.) diameter duct from the hood is 6,200 ft³/min. Use standard temperatures and pressures.

Solution:

To calculate the hood static pressure (SPh), use the following equation:

$$SPh = -VP - (F_h \times VP)$$

Velocity Pressure

Calculate the velocity pressure (VP) using the following equation. At standard conditions,

$$VP = \left(\frac{V}{4005} \right)^2$$

$$V = \frac{Q}{A}$$

Given $Q = 6200 \text{ ft}^3/\text{min}$

$$\text{Area of the duct, } A = \frac{\pi d^2}{4}$$

$$\text{Area of the duct, } A = \frac{3.14 \times 1.5^2}{4}$$

Area of the duct, $A = 1.766 \text{ ft}^2$

$$V = \frac{Q}{A}$$

$$V = \frac{6200}{1.766} = 3510 \text{ ft/min}$$

$$VP = \left(\frac{3510}{4005} \right)^2 = 0.77 \text{ in. WC}$$

Hood Entry Loss

Calculate the hood entry loss (He) as follows:

$$He = Fh \times VP$$

$$He = 0.49 \times 0.77 = 0.38 \text{ in. W.C}$$

Hood Static Pressure

Calculate the hood static pressure (SPh)

$$SPh = - (0.77 + 0.38) = -1.15 \text{ in. W.C}$$

5.9 Good Practices

Here are some tips on how you can ensure the efficiency of your dust collection hood:

- a. The number and placement of the collection points depends on:
 - The type of material collected
 - The workstation where material is collected
 - The capture velocity requirements
 - Types of material being collected
- b. Dust collecting systems with an excessive number of connected vent points cannot be controlled / calibrated in a way that pollution control is effective. A good practice is to limit the number of vent points connected to one filter to a maximum of 8 points.
- c. Unplanned additions may cause a system to fail, by changing the pressure distribution in the system and reducing face velocities at other hoods. In principle, changes should be avoided, and, if any are made, they must be carefully considered and engineered.
- d. A system designed for a type of contaminant cannot usually handle other contaminants.
- e. The hood should have a 45° sloped transition into the duct.
- f. Install Blast Gates after the hood to allow for system balancing. Routinely monitor Blast Gates and adjust to obtain 1-inch WG suction at the hood exit.

6 CHAPTER – 6: GUIDELINES FOR YOUR DUCTWORK

The purpose of the ductwork is to carry the contaminated air from the collection hood to the collector. Duct sizing is based on following variables:

- What volume of air is being moved?
- What kind of dust and/or particles are being collected?
- What are the requirements for conveying velocity?

6.1 Types of Industrial Ductwork

The industrial duct network can be routed as tapered system or plenum system.

6.1.1 Tapered Duct System

The ductwork becomes larger closer to the collector as more airflow branches are introduced. The velocities are nearly constant as the airflow is blended and the duct becomes larger. Tapered systems are typically used for dust collection systems.

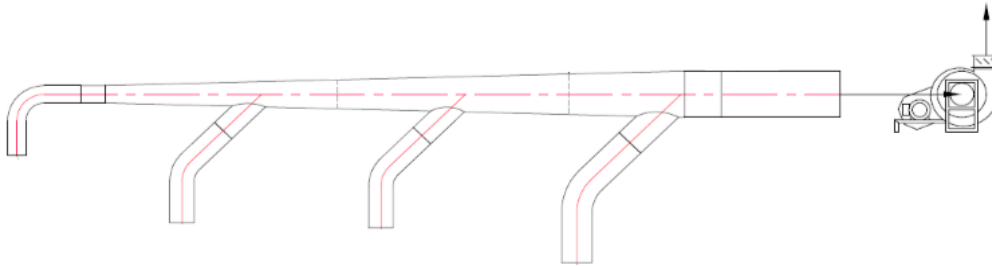

Figure 17. Tapered System

6.1.2 Straight Duct System

The straight duct system is easier, simpler, and less expensive to install but with several pickup points, the velocity of the air in the duct is usually lower and dust may fall out of the air stream and pile up. A straight duct system is commonly used for HVAC and fume extraction, however it is not a good choice for a dust collection system.

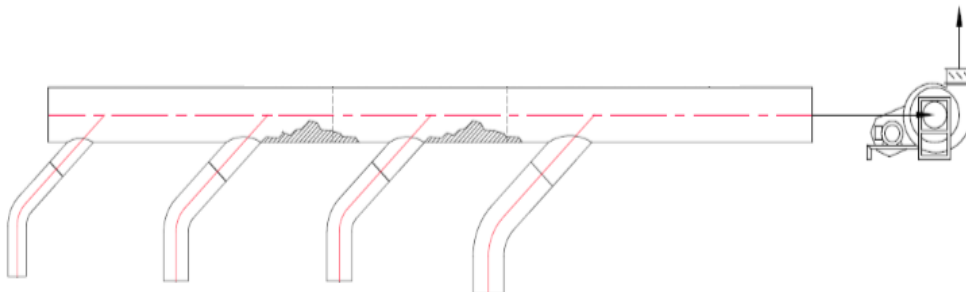

Figure 18. Straight Duct System

6.2 Conveying Velocities

The proper conveying velocity will be determined by the type of dust being transported.

A general rule of thumb for good ductwork design for average industrial dust is to size the cross-sectional area for a velocity of 3,500-4,000 FPM (18–20 m/sec).

6.2.1 Effects of Conveying Velocity

Dust in the airstream will fall out of ducts at velocities less than 3500 fpm, causing dust build-up in the duct. Aside from the hassle of frequent cleaning, certain dust accumulations have the potential to ignite and cause a flammable dust explosion. The lower velocity will also lead to larger ducts and high capital costs.

Ducts with higher velocities exceeding 4000 FPM may cause rapid abrasion of ductwork. At some point, this will need to be changed at an additional cost. Transporting the dust faster will require smaller ductwork but may require a bigger fan than you really need. These fans are more expensive to purchase and operate.

6.2.2 Recommended Conveying Velocity

A good rule of thumb is the heavier the dust, the higher the velocity. And the higher the velocity, the higher the potential operating costs. The following are the recommended conveying speeds:

Nature of Contaminant	Examples	Design Velocity, FPM
Vapors, gases, smokes	Solvent, oil smoke, plasticizer smoke	1,000-2,500
Fumes	Welding	2,000-2,500
Very fine light dusts	Wood flour, litho powder, toner	2,500-3,000
Average industrial dusts	Sawdust, grinding dust, buffing lint (dry), mineral dust, general materials handling, carbon dust, alumina dust, foundry dust, limestone dust, cement,	3,500-4,500
Heavy dusts	Metal turnings, wood hog waste, brass turnings, lead dust	4,000-4,500
Heavy high density coarse dust or moist dusts	Lead dust with small chips, moist cement dust, buffing lint (sticky), pneumatic conveying	4,500 and up

Table 2. Recommended Conveying Velocity

6.3 Duct Sizing Calculations

The following formulae include all the values used in duct sizing:

6.3.1 Duct Conveying Velocity and Air Volume

Air volume (ft³/min) = Air velocity (ft/min) x Duct area (ft²)

Or

Duct area (ft²) = Air volume (ft³/min) ÷ Air velocity (ft/min)

Or

Air velocity (ft/min) = Air volume (ft³/min) ÷ Duct area (ft²)

6.3.2 Example:

A duct system conveying a very light dust requires a minimum transport velocity of 2,800 ft/min. The volumetric flow rate for the system is 978 CFM. What is the necessary duct diameter in inches for this section of ductwork to maintain the minimum transport velocity?

Solution:

$$\text{Duct area (ft}^2\text{)} = \text{Air volume (ft}^3\text{/min)} \div \text{Air velocity (ft/min)}$$

$$\text{Air velocity} = 2,800 \text{ ft/min}$$

$$\text{Gas volume} = 978 \text{ ft}^3\text{/min}$$

$$\text{Duct area} = \frac{978}{2800} = 0.349 \text{ sq. ft}$$

$$\text{Duct area (ft}^2\text{)} = \pi \times \text{Duct diameter}^2/4$$

$$\text{Duct Diameter}^2 = 4 \times \text{Duct area (ft}^2\text{)} \div \pi$$

$$\text{Duct Diameter}^2 = 4 \times 0.349 \text{ ft}^2 \div 3.14$$

$$\text{Duct Diameter}^2 = 0.444$$

$$\text{Duct Diameter} = (0.444)^{1/2} = 0.66 \text{ ft} \text{ ----- or } 0.66 \times 12 = 8 \text{ inches}$$

Notes:

- a. If the ductwork is sized too small, the velocities will be high and result in high pressure loss, high energy use and increased wear. This is evident in the large percentage of ductwork with holes and patches.
- b. If the ductwork is sized too large, the velocities will be too low, and result is dust fallout and build-up in the duct.

6.4 Duct Materials

The ducts can be of many varied materials, from PVC to galvanized steel to stainless steel, depending upon the materials to be conveyed or the code requirements of the particular industry. Important considerations in the choice of duct material are physical abrasion, corrosiveness of the air contaminant and temperature of the effluent.

- a. Ducts can be fabricated of galvanized steel or mild steel, ASTM A284 gr. C, D. The sheet metal shall be of minimum 11-gauge (3 mm) thick and corrosion resistant.
- b. Stainless steel 316L is recommended for food handling, pharmaceuticals, and certain chemicals. Stainless steel may be 14 gauge (1.98 mm) or thicker. Special stainless-steel alloys must be used at temperatures above 300°F.
- c. Rigid polyvinyl chloride (PVC) and glass-reinforced polyester resins (FRP) are widely used wherever corrosive effluents are handled. Caution: If you're going to use plastic materials, be sure your system is grounded. Static electricity is created by some dust grains, such as wood, and because plastic is not conductive, a static charge can develop and release, resulting in sometimes shocking outcomes.
- d. Aluminium sheet or plastics such as polypropylene may be used for light duty and low temperature applications (less than 100°F).

6.5 Duct Shapes

Design and selection of ducts shall be based on SMACNA (USA) or EN 1506/EN 12237 for dimensions, strength, and tightness (Europe). Circular duct cross-section shall be used for dust collection.

6.5.1 Circular Ducts

Table below provides recommended material thicknesses of circular ducts as a function of duct diameter (D).

Diameter (D)	D < 16 inch D < 400 mm	16" ≤ D < 32" 400 ≤ D < 800	32" ≤ D < 40" 800 ≤ D < 1000	D ≥ 40" D ≥ 1000
Wall Thickness (t)	t = 22 gauge t = 0.75 mm	t = 20 gauge t = 0.9 mm	t = 18 gauge t = 1.2 mm	t = 10 gauge t=3.0 mm

Table 3. Recommended Material Thicknesses of Circular Ducts

6.5.2 Rectangular Ducts

Rectangular ducts shall only be used for low velocity (< 2500 FPM) and low negative and positive pressure applications. The following table depicts minimum requirements for duct thicknesses.

Side Length (L)	L < 10 inch L < 250 mm	10 ≤ L < 20 inch 250 ≤ L < 500 mm	L ≥ 20 inch L ≥ 500 mm
Wall Thickness (t)	t = 26 gauge t = 0.5mm	t = 24 gauge t = 0.6 mm	t = 20 gauge t = 0.9 mm

Table 4. Minimum Requirements for Duct Thicknesses

6.6 Duct Static Pressure

Static pressure is resistance to flow caused by friction and the channeling of airflow through a duct. It's measured in "in-WC" inches of water column.

Higher pressure losses in the ductwork will reduce air volume entering the collection hood and degrade the performance of the dust collector. It is important to minimize the pressure losses. The air velocity required to carry gathered dust is an important factor to consider. More losses will result with higher velocity. Consider the following scenario:

For a 100-foot duct, the pressure loss would be 1.37 in-WC at 3500 fpm.

For a 100-foot duct, the pressure loss would be 2.52 in-WC at 4500 fpm.

The slower speed thus saves $2.52 - 1.37 = 1.15$ in-WC.

Therefore, conveying material at 4500 FPM when the identical work can be done at 3500 FPM is not advisable.

The sharper the elbows and branch entries, the higher the pressure losses. For example, a 45° branch entry at 4000 FPM will result in a pressure loss of 0.28 in- WC. In comparison, the pressure loss on the 30° branch would be 0.18 in-WC. Similarly, duct elbows with a radius of 1.5 diameter can lose 0.24 in-WC. In comparison, a 2.0 duct elbow radius, on the other hand, can result in a loss of 0.19 in-WC.

6.7 Ductwork Layout

- a. The length of the ductwork should be as short as possible.
- b. The dust collector's ductwork should have a straight run of at least eight diameters.
- c. Ducting should be horizontal or vertical, not at an angle.
- d. Ducting should be preferably round with smooth internal finish. Tapers on transition sections used to connect to rectangular equipment must be no more than 12 degrees.
- e. Cleanouts shall be provided at the beginning of each horizontal section. Elbows must not have cleanouts attached to them. Inspection doors should be installed and placed at regular intervals, especially after branch junctions or changes of direction.

6.7.1 Duct Branches

- a. Use a WYE fitting instead of a TEE for splitting the pipe into many runs.
- b. The angle of entrance for branches should be no more than 45 degrees from the centerline of main path.
- c. A branch should enter the main at the larger end of a transition piece, not ahead of the transition.
- d. A branch should never be allowed to enter the bottom of a main or an elbow.

6.7.2 Elbows

- a. Use flat-back to avoid wear on metal.
- b. Straight ducting before and after a 90° elbow should be minimum 5 diameters length. 7 diameters is the best practice.
- c. Elbows should be two gauges heavier than straight lengths. Unless otherwise specified on designs, elbows must be 2 times the diameter radius.
- d. 90° elbows with a diameter of up to 8 inches (200 mm) must be built in five sections, from 9 inches to 18 inches (225 to 450 mm) in seven sections, and over 18 inches (450 mm) in nine sections.
- e. Elbows must not be connected to fan intake connectors directly. Between the elbow and the fan inlet, a straight segment of duct at least 3 times the diameter in length shall be used.

6.7.3 Dampers (Blast/Knife gates)

Dampers shall be provided where possible to help balance the system. If used in branch lines, these shall be installed close to the entrance to the main. They shall not immediately follow a hood.

6.7.4 Expansion joints

Expansion joints shall be utilized in high temperature systems to maintain a sealed system across a wide gas temperature range.

6.7.5 Flexible joints

Provide flexible joints in high vibration areas especially around shaker screens and fan inlets/outlets, etc.

6.7.6 Supports

Ducting should be rigidly supported every 10 to 13 ft. (approx.3 to 4 meters).

6.7.7 Leakage

After installation, system shall be leak tested at the maximum expected static pressure. Leakage should be no more than 1% of the design volume.

6.8 Good Practices

Frequently encountered ductwork problems are poorly designed branch entries, elbows and size variations that hamper airflow and/or cause accelerated wear. Correct and incorrect ductworks are shown for your reference below:

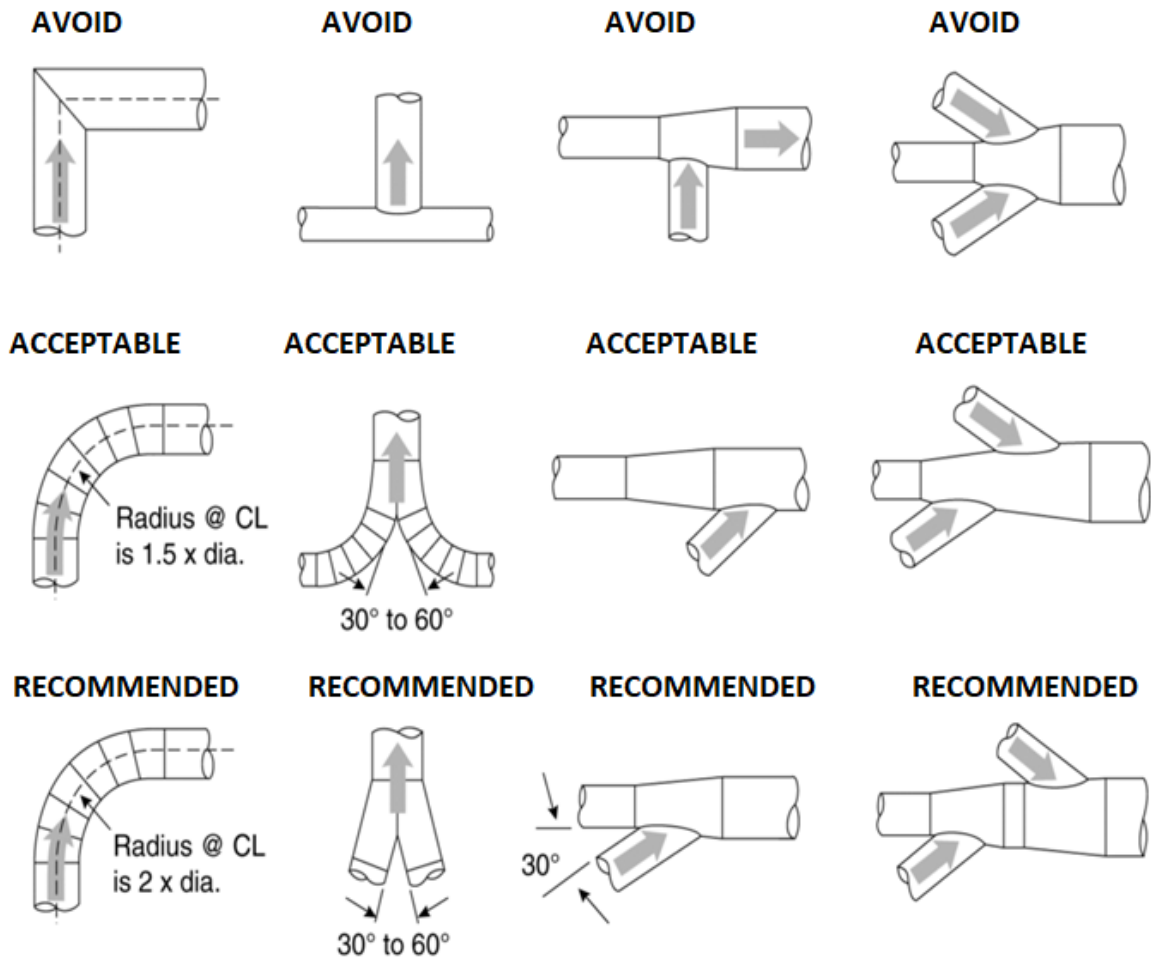

Figure 19. Recommended Duct Layouts

6.9 Baghouse Outlet Ductwork

The Outlet Ductwork is also known as the “Exhaust Duct or Stack.” The stack shall be designed and installed to facilitate for the exhaust air to escape the building/structure envelope and provide sufficient dispersion so that the plume does not cause an unacceptable situation when it reaches the ground. As a rule of thumb, the stack should be terminated 10 ft. (3 meter) over the nearest building structure. A good stack velocity is 3000 FPM and the outlet ductwork cross-section should match the fan discharge outlet.

7 CHAPTER – 7: GUIDELINES FOR YOUR FILTER MEDIA

The filter element is the most important component of the air cleaning system. If the media do not match the job parameters, the bags will fail prematurely, and the dust collection performance will be degraded.

Abrasion, temperature excursions, and chemical attack are three key failure modes that limit bag working life.

The filter medium must satisfy the following conditions:

- a. High air permeability
- b. Good mechanical strength
- c. Good thermal stability at operational temperature
- d. Good dimensional stability at operational temperature

7.1 Design Parameters

Important design parameters are:

- a. Filter type, particularly cleaning principle
- b. Moisture level
- c. Gas temperature (average and peaks)
- d. Composition and chemical properties of the gas
- e. Raw gas dust load, particle size
- f. Particulate abrasiveness
- g. Allowed dust load in the clean gas
- h. Physical and chemical properties of the dust.



Figure 20. Filter Bags

7.2 Fabric Types

7.2.1 Woven Fabric

A woven fabric is composed of interlaced yarns. The fabric's strength is provided by yarns in the "warp" direction, while the fabric's qualities are determined by yarns in the "fill" direction. Pores, or gaps between the strands, can be as large as 2 inches (50 mm) in diameter. Small particles move through these pores easily until they are caught on the yarns' sides and bridge over the openings.

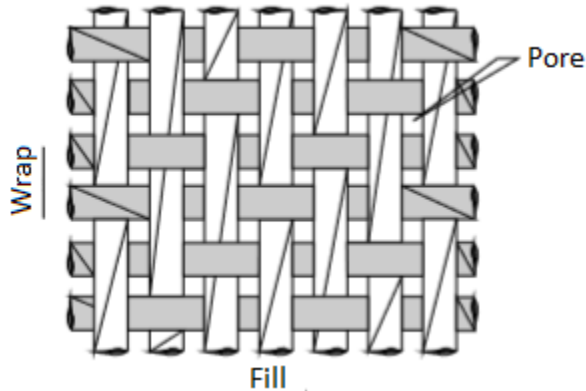

Figure 21. Woven Fabric

Woven fabrics offer low resistance to flow and good release characteristics and are commonly used for reverse air and shaker baghouses.

7.2.2 Felted Fabric

Felted fabrics are made from fibers that are randomly arranged and linked to a very open weave termed the scrim. The felted fabrics are usually much thicker than woven cloths due to the layer of fibers on both sides of the scrim. There are no pores in this sort of fabric fabrication. The fibers on the filtering ("dirty") side provide a high number of targets for particle impaction, Brownian diffusion, and electrostatic attraction.

Non-woven fabric types have higher resistance to flow but offer longer bag life and higher collection efficiencies. These are commonly used in pulse jet baghouses.

7.2.3 Membrane Fabric

Membranes are the most adaptable filter media available. This filter medium contains a very thin, micro-porous coating on the filtration surface with pores so small that water molecules – and submicron particles – cannot get through. A polytetrafluoroethylene (PTFE) membrane is laminated to a woven or felted support fabric to create these. The membrane is placed on the filtering side of the fabric. Particle collection occurs primarily due to the sieving action of the membrane's very small pores (less than 5 μ m). The dust layer plays a minor role in particulate removal in membrane fabrics. Furthermore, due to the good dust cake release capabilities, static pressure drop is relatively low.

7.3 Fabric Materials

The fabrics used for baghouses can be composed of a variety of synthetic and natural materials. Selection of the fabric material is based primarily on four criteria.

- a. Maximum gas temperatures of the gas stream
- b. Corrosive chemical concentrations in the gas stream
- c. Physical abrasion and fabric flex conditions
- d. Costs

The most common natural materials are cotton and wool. These are inexpensive but are susceptible to failure at high temperature and chemical attack.

The synthetic fabrics are superior in handling harsh industrial dusts. The temperature, abrasion and acid-resistant capabilities of some of the commercially available synthetic fabrics are summarized in Table below. (Source: GE Energy).

Acronyms

E: Excellent

G: Good

F: Fair

P: Poor

Fabric Material		Cost	Maximum Continuous Operating Temp.	Resistance against			
				Abrasion	Filtration Properties	Alkaline	Acids
Generic Name	Common Trade Name						
Polypropylene	Polypropylene	\$	180°F (88°C)	E	G	E	E
Acrylic	Orlon®	\$	260°F (127°C)	G	G	F	G
Polyester	Dacron®	\$	275°F (135°C)	E	E	F	F
Polyphenylene Sulfide (PPS)	(Ryton®)	\$\$	375°F (190°C)	G	E	E	E
Aromatic Polyamide	Nomex®	\$\$	400°F (204°C)	E	E	G	F
Polyimide	P84	\$\$\$	500°F(260°C)	F	E	F	G
Fiberglass	Fiberglass	\$\$\$	500°F (260°C)	F	F	F	P
Polytetrafluoroethylene (PTFE)	Teflon®	\$\$\$\$\$	450°F (232°C)	G	F	E	E

Fabric Material		Cost	Maximum Continuous Operating Temp.	Resistance against			
Generic Name	Common Trade Name			Abrasion	Filtration Properties	Alkaline	Acids

Table 5. Fabric Materials

7.3.1 Characteristics & Applications

Following table summarizes important characteristics and use of various fabric materials.

Fabric Material	Characteristics and Use
Polypropylene	This synthetic is available in both continuous filament and staple fiber form and is produced as either a felt or woven material. Its primary benefit is that it is non-hygroscopic (does not chemically react with water). It exhibits great resistance to static build-up and abrasion and provides a slick surface for good dust cake release during bag cleaning. Its major limitation is its low maximum continuous operating temperature of 180°F (88°C). Oxidizing agents, copper, and related salts damage polypropylene. Polypropylene is widely used in the food, detergent, chemical processing, pharmaceutical, and tobacco industries.
Acrylic	These synthetic fibers offer good hydrolytic resistance over a limited temperature range, 260°F (127°C) continuous and 275°F (135°C) surge application. Acrylic fibers are used in the manufacture of ferrous and nonferrous metals, carbon black, cement, lime and fertilizers. They are also used extensively in wet-filtration applications.
Polyester	Polyesters are among the most widely used fabrics for general applications below 275°F (135°C). Polyester fibers are produced in both filament and staple form and are available in both woven and felted fabrics. They have good resistance to weak alkalies and fair resistance to strong alkalies at low temperatures. They have good resistance to most oxidizing agents and excellent resistance to most organic solvents. The primary damaging agents are water (hydrolysis) and concentrated sulfuric, nitric, and carbolic acids.
PPS[Ryton®]	This is a synthetic fiber developed by Phillips Fibers Corp. It has a moderate temperature range, 375°F (190°C) continuous, 450°F, (232°C) surge. It will hydrolyze, but only at temperatures above 375°F (190°C). It has excellent resistance to both acids and alkalies, which makes it very useful in combustion-control applications. Its early applications have been on industrial coal-fired boilers, waste-to-energy incineration (with and without spray dryers), titanium dioxide, and installations where

	Nomex does not perform well due to chemical or hydrolytic attack.
Aramid [Nomex®]	This is a commonly used fiber for applications in the 275-400°F (135-204°C) range. It is produced in both filament and staple fiber form and is available as both woven and felted fabrics. It has excellent thermal stability, shrinking less than 1% at 350°F (177°C). The fiber is flame resistant, but when impregnated with combustible dusts, will support combustion that will melt and destroy the fabric. Nomex will begin to hydrolyze at 375°F (190°C) when the relative humidity is 10% or greater. Hydrolysis changes the normal white or gray fabric to a red-brown color. The presence of acids will catalyze the hydrolysis process. Unacceptably short bag life will result where sulfur oxides (SO _x) and moisture are present and frequent dew point excursions occur, such as in coal-fired boilers. Some acid-retardant finishes have been developed for Nomex but have been found to improve bag life by no more than 50%, leaving most bag life cycles unacceptably short.
P84	P-84 is an aromatic polymer fiber produced in felt form only. The unique shape of the fiber produces improved capture efficiency characteristics. This fabric is specified at 500°F. Composites are available that take advantage of the superior filtration characteristics of P-84 while reducing its cost. Any of the previous felted materials can be combined with P-84 to produce a fabric composite that exhibits the characteristics of both materials.
Fiberglass	Most fiberglass fabrics are woven from minute 0.00015-inch (.0038 mm) filaments. Many variations of yarn construction, fabric weaves, and fabric finishes are available. It is also produced in a felted form. Fiberglass has the highest operating temperature range available in conventional fabrics: 500°F (260°C) continuous, 550°F (288°C) surge. Above 500°F (260°C), the fiberglass itself is not directly damaged, but the finish which provides yarn-to-yarn lubrication begins to vaporize, resulting in accelerated mechanical wear of the glass fibers. Fiberglass is noncombustible, has zero moisture absorption (cannot hydrolyze), has excellent dimensional stability, and has reasonably good strength characteristics. Woven glass fabrics have high tensile strength characteristics but relatively low flex strength, especially in the fill (circumference) direction of the bag, and low abrasion resistance. Care must be taken to minimize flexing and rubbing. Fiberglass fabrics have relatively good resistance to acids, but impurities in the glass fibers are attacked by hydrofluoric, concentrated sulfuric and hot phosphoric acids. They also have poor resistance to hot solutions of weak alkali's, acid anhydrides, and metallic oxides. For these reasons, glass fabrics should not be operated below the acid dew point. Fiberglass fabrics are used extensively with coal-fired boilers and high

	temperature metals applications.
Teflon® (PTFE)	Teflon® is unique among synthetics in its ability to resist chemical attack across the entire pH range throughout its operating temperature range of 450°F (232°C) continuous, to 500°F (260°C) surge. This fluorocarbon fiber is non-adhesive, has zero moisture absorption, and is unaffected by mildew or ultraviolet light. The primary shortcomings of Teflon® are its high cost and relatively poor abrasion resistance. However, the higher cost can often be justified through longer bag life in extremely corrosive atmospheres. Felted Teflon® is also produced in combination with staple glass fibers and marketed by DuPont as Tefaire®. This combination produces some improved filtration and flow characteristics. Applications of Teflon® include coal-fired boilers, waste-to-energy incinerators, carbon black, titanium dioxide, primary and secondary smelting operations, and chemical processing.

Table 6. Important Characteristics and Use of Various Fabric Materials

7.4 Surface Treatment of Filtration Media

Various treatments and finishes can be applied to the basic fabric to enhance the filter media performance. The principal objective is to reduce the adhesion of caked solids to the fabrics, and thus make the cleaning process easier and more effective. The other objective is to improve their ability to withstand acid attack and abrasion/flex type physical damage.

A common additive is graphite, which improves the electrical conductivity of the fabric. This dissipates electrical charge and reduces the explosion risk when dealing with flammable dusts. PTFE coatings can improve the fabric strength and cake release characteristics.

Following finishes are available for non-fiberglass.

Finish	Purpose	Available For
BHA-TEX® Expanded PTFE Membrane	For capture of fine particulate, improved filtration efficiency, cake release, and airflow capacity	Polyester, Nomex, Acrylic, Polypropylene (felt and woven), P84, PPS, Teflon/PTFE
Singe	Recommended for improved cake release	Polyester, Polypropylene, Acrylic, Nomex, PPS, P84 (felts)
Glaze/Eggshell	Provide short-term improvements for cake release (may impede airflow)	Polyester, Polypropylene (felts)
Silicone	Aids initial dust cake development and provides limited water repellency	Polyester (felt and woven)
Flame Retardant	Retards combustibility (not	Polyester, Polypropylene (felt

	flame- proof)	and woven)
Acrylic Coatings (Latex Base)	Improved filtration efficiency and cake release (may impede airflow in certain applications)	Polyester and Acrylic felts
PTFE Penetrating Finishes	Improved water and oil repellency: limited cake release	Polyester, Nomex (felt), PPS

Table 7. Finishes for Non-Fiberglass

All fiberglass fabrics must have coatings to protect the relatively brittle fibers that can easily be broken by fiber-to-fiber abrasion. Silicone-graphite finishes for fiberglass fabrics are common. Other coatings include Teflon®B, I-625®, Blue Max®, and Chemflex®. Following finishes are available for fiberglass.

Finish	Purpose	Applications
BHA-TEX® Expanded PTFE Membrane	For capture of fine particulate, improved filtration efficiency, cake release, and airflow capacity	Cement/lime kilns, incinerators, coal-fired boilers, cupola, ferro-silica/alloy, furnace
Silicone, Graphite, Teflon®	Protects glass yarns from abrasion, adds lubricity	For non-acid conditions, primarily for cement and metal foundry applications
Acid Resistant	Helps shield glass yarn from acid attack to extend life	Coal-fired boilers, carbon black, incinerators, cement, industrial, and boiler applications
Teflon® B	Provides enhanced fiber to fiber resistance to abrasion and limited chemical resistance	Industrial and utility base load boilers under mild pH conditions, cement, and lime kilns
Blue Max CRF-70®	Provides improved acid resistance and reduces fiber to fiber abrasion, resistant to alkaline attack, improved fiber encapsulation	Coal-fired boilers (high and low sulfur) for peak load utilities, fluidized bed boilers, carbon black, incinerators

Table 8. Finishes for Fiberglass

For applications that demand the highest filtration efficiencies (near ZERO emissions), the filter media may be laminated with expanded PTFE membrane (e.g. BHA-TEX® / GORE-TEX®). These membranes have a very small pore size, and arrest particles at the surface of the fabric, preventing penetration. The membrane raises the initial filter resistance slightly; however, the reduction in blinding means that the resistance increases less during operation, so that the resistance may be lower on average over the lifetime of the bag.

7.5 Filter (Weight/Area)

Apart from the properties of the fibers themselves, specifications for filter fabrics should include the 'weight per unit area', which gives an indication of the thickness, and therefore the strength and durability of the fabric, and an indication of its permeability. The permeability of the material depends upon the construction of the fabric, which depends on whether it is woven or nonwoven/felted, its thickness, tightness of weave, and so on. This information allows an estimate of the pressure drop across a filter to be made.

For general applications, it is recommended that weight of nonwoven/felted fabric should be 475 g/m² to 543 g/m².

8 CHAPTER – 8: GUIDELINES FOR HOPPER AND AIRLOCK

The Hopper is the entry point for the captured dust and dirty air. In fact, it is perhaps the single most important element in allowing long filter life. A large hopper allows the air velocity to slow down as it comes in from the ducting. This reduces the chance of abrasion as the cause of filter failure.

Finally, the dust that has accumulated in the hopper must be removed from the dust collector. If dust is allowed to accumulate in hoppers, the air stream that enters the hopper lifts the dust and collects it on the filters. This induces a circulating dust load in the dust collector, causing filters to be cleaned at an increased pace, raising differential pressure and shortening filter life.

For auto operation, the conveying equipment and air locks should be installed beneath the hopper. There will be a flow of air up through the hopper against the flow of material you are trying to release from the hopper if there is no air lock. This will create another entrainment of previously collected dust. Once again, this necessitates greater filter bag cleaning and, as a result, a higher differential pressure.

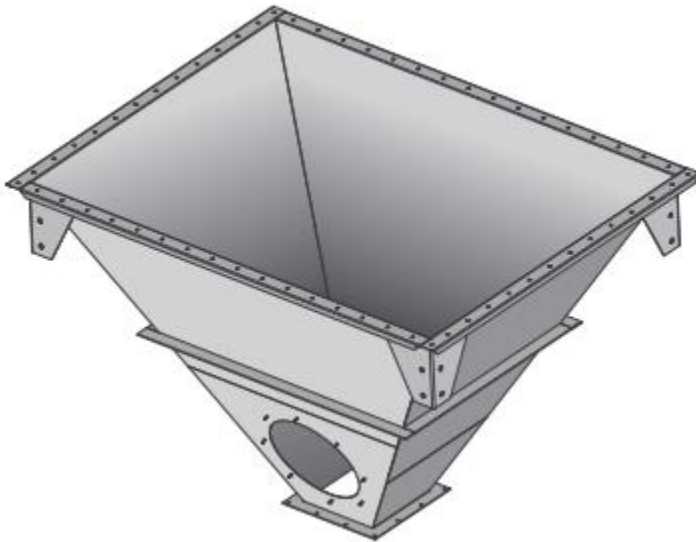

Figure 22. Dust Hopper

8.1 Hopper Design

The hopper design is dependent on the dust repose angle representing the maximum angle relative to horizontal at which the dust will flow.

It is critical to have steeper hopper walls to lessen the possibility of bridging by limiting the amount of dust that can accumulate on the hopper's side walls.

8.1.1 Design Tips

Here are few design tips:

- a. **Tip 1:** To ensure a tight and smooth fit, match the size of the baghouse flange to the hopper flange.

- b. **Tip 2:** Check for any "Ridge" or "Shelf" between the hopper and the baghouse that could allow material to collect on the edges.
- c. **Tip 3:** To avoid fugitive emissions or air infiltration, make sure there are no leaks between the hopper and the baghouse.
- d. **Tip 4:** The ductwork shall be designed to slow the air speed to 2,500 FPM or lower, with a transition piece from the duct to the hopper. Slowing the air speed allows the heavy dust particles to drop out and into the hopper. This will require increasing the cross-sectional area in the transition zone to reduce the gas velocity.
- e. **Tip 5:** A sticky or moist dust may require steeper sided hoppers, a nonstick internal hopper coating, or both. Dry, fine bulk type dust, agglomerative dust, and hygroscopic dust may require larger than standard hopper discharge openings and larger airlock valve.
- f. **Tip 6:** Provide an electronic measuring device to monitor the waste level inside the baghouse hopper.

8.2 Airlocks

An "Airlock" sits at the bottom of the hopper, acting as an air seal to prevent leaks or infiltration through the dust discharge valve.

Why it is important!

- a. The airlock permits material to continuously flow out of the hopper.
- b. Airlock allows you to change the dust bin without turning the system off. If you don't have an airlock, you'll have to turn off the system or operate the unit without isolation if you need to change your dust bin.
- c. Airlock acts as a seal by maintaining a constant air pressure or vacuum differential between the inlet and exit ports. Because most dust collectors work under negative pressure, air will permeate the system if there isn't an airlock in place. Moisture from outside the collector may enter the hopper due to air leakage. As a result, dust that is normally dry can turn sticky and start caking.

8.3 Types of Airlocks

8.3.1 Rotary Valves

Rotary valves are the most used devices in dust collector hopper discharges which requires a seal between the atmosphere and the dust hopper. The valve acts both as airlock and metering device.

The discharge falls into the rotating airlock from the hopper. The paddle wheels are rotated at a set speed by a motor drive, and the particles are eventually evacuated from the bottom of the system without breaking the air seal. Rubber extensions on the paddle wheels keep the system hermetically sealed and collect the discharge.



Figure 23. Rotary Airlock Valve

Caution: The valve is used in dust collectors to control differential pressure. The rotary airlock valve will need to be sized to tolerate higher dust discharge rates if dust falls after the fan is turned off. If the rotary airlock valve is set to close when the fan stops, dust that falls into the hopper is trapped until the system is restarted. This can lead to more bridging, as well as other issues. Any rotary airlock valve, whether indoors or outdoors, must have a time delay to ensure the hopper is totally empty before it is turned down.

8.3.2 Knife Gate Valve

A knife gate valve uses a linear motion of blade, which advances until the passage is closed, or it withdraws until the passage is open. In the closed position, the knife gate valve is designed to seat tightly and prevent the loss of positive or negative pressure of the system. When the valve is open, the system must be able to withstand a loss of pressure.

8.3.3 Double Dump Valve

The Double-Dump valve is essentially two valves in series. And while one of the valves is open, the other is closed. This prevents air from leaking in or out since there is no direct opening through the valve. The major drawback of this valve is that the capacity of the valve is severely restricted. Through the same diameter valve, a rotary valve will have a larger flow rate. The benefits include the ability to handle chunky or fibrous materials that might otherwise jam standard rotary valves, as well as the durability to handle abrasive materials.

8.3.4 Trickle Valve

A trickle valve uses the vacuum of the system to seal a sleeve. This prevents air from leaking into the system. Gravity will then pull the dust through the sleeve once enough material is built up above the valve. This valve can be used if: the system has negative pressure; the dust is free-flowing dust and won't bridge; and the dust is not explosive. A trickling valve has no moving components, is inexpensive, has little maintenance, and requires no power.

8.3.5 Selection Choice for your Application

1. **Rotary valve**– Rotary valves have a very little air leakage across the valve, which is usually not a big deal with many applications, but air leakage can cause major issues with some hygroscopic dusts. Do your research carefully.

2. **Double dump valve**– Use this if you want to minimize air leakage. The Double Dump works well with big, chunky material or if you’re worried the material may wrap around a rotary valve rotor.
3. **Trickle valve** – Use to save money and time. It’s low cost and easy maintenance.
4. **Knife Gates**– Used for periodic emptying of the dust collector hopper into another container. Knife gates come in a variety of design (knife gate, slide gate, orifice type, etc.). Depending on the design, they can provide a tight air seal, however when open, the airlock is lost.

8.3.6 Final Disposal

The final point to consider is how to deal with the waste that has been gathered. The waste could be pumped into a bin, dumpster, silo, or trailer by gravity. Installing a pneumatic relay system, which employs a blower to force the material into a silo or trailer, is another option. The final option is to move the material to the storage area using mechanical conveyors. Mechanically conveying to multiple locations is done with augers, bucket conveyors, and drag conveyors.

CHAPTER – 9: GUIDELINES FOR YOUR FAN AND MOTOR

The selection of the appropriate air moving device (fan) is based on the system design criteria which include air volume, static pressure, and possible particulate contamination.

An improperly sized fan can hinder the performance of the other components (hood, ductwork, dust collector). The fan should be sized to handle a specific volume of air at a specific system pressure. If the fan is too small, it will not be able to move the required amount of air. When a fan moves more air volume than is required, it imposes undue stress on the entire system, which leads to numerous maintenance problems.



Figure 24. Air Moving Device

9 Fan Affinity Laws

Determining the fan size and air pressure requires employing several formulas and best practices also known as “Affinity laws”. These offer a precise method for addressing the broad array of variables.

Airflow (CFM) Varies Directly as the Fan Speed (RPM):

$$\text{RPM}_2 = \text{RPM}_1 (\text{CFM}_2 \div \text{CFM}_1)$$

$$\text{CFM}_2 = \text{CFM}_1 (\text{RPM}_2 \div \text{RPM}_1)$$

Fan Power (HP) Varies as the Cube of the Fan Speed (RPM):

$$\text{HP}_2 = \text{HP}_1 (\text{RPM}_2 \div \text{RPM}_1)^3$$

$$\text{RPM}_2 = \text{RPM}_1 (\text{HP}_2 \div \text{HP}_1)^{1/3}$$

Fan Static Pressure (SP) Varies as the Square of the Fan Speed (RPM):

$$\text{SP}_2 = \text{SP}_1 (\text{RPM}_2 \div \text{RPM}_1)^2$$

$$\text{RPM} = \text{RPM} (\text{SP} \div \text{SP})^{1/2}$$

9.1 Classification of Fans

Fans are classified as axial-flow fans and centrifugal fans.

9.1.1 Axial Fan

The axial-flow fan category includes propeller fans, tube-axial fans, vane-axial fans, and two-stage axial-flow fans. Axial flow fans move the air in a direction that is "axial" or parallel to the axis of rotation of the fan.

9.1.2 Centrifugal Fan

The airflow for a centrifugal fan is different from that of axial flow fans. For a centrifugal fan the airflow is drawn into a rotating impeller and discharged radially from the fan blade. The resulting flow of air is perpendicular to the axial rotation or parallel to blade motion and the housing is used to direct the airflow to the desired location.

9.2 Type of Fans

The selection of the appropriate air moving device (fan) is based on the system design criteria which include air volume, static pressure, and possible particulate contamination. The most used fans in dust collectors are:

9.2.1 Forward Curved Fan

The forward-curved wheel is used for low to medium air volumes with low to medium static pressure requirements. The advantages of the forward-curved fans include low cost and quiet operation. The pressure curve of a forward-curved fan is not as steep as that of a backward-inclined fan. The pressure curve has a dip to the left of the peak static pressure, therefore picking operating point must be done with caution. The horsepower curve continues to grow when static pressure is lowered, and the fan pushes more air. This must be considered while choosing the right motor horsepower.

9.2.2 Radial Blade Fan

The radial blade wheel is used for low to medium air volumes with medium to high static pressure requirements. The wheel blades are perpendicular to the direction of the wheel's rotation and the fan runs at a relatively medium speed to move a given amount of air. The advantages of the radial blade fans include low cost, high static pressure capabilities and the ability to operate in contaminated air streams. The radial blade fan is the least efficient of the centrifugal fans but is ideal for material handling applications.

9.2.3 Backward Inclined

The backward-inclined wheel is used for medium to high air volumes with medium static pressure requirements. The wheel blades are flat and angled outward from the rotational direction of the fan wheel. Backward-inclined fans provide several advantages, including low cost, consistent performance, and non-overloading (horsepower) characteristics.

9.2.4 Backward Curved

Backward curved fans are similar to backward inclined fans, except the blades are slightly curved. These blades are better suited to handle contaminated air because they are single thickness and can be made of heavier material that can resist the effects to fan blades by the

contaminated air. The backward curved fan is quieter, more efficient, and capable of higher pressures than the backward inclined fan. There is no overloading in the fan horsepower curve.

9.2.5 Airfoil Fan

The airfoil wheel is like a backward-inclined wheel in its operating characteristics. The airfoil fan's key advantage is its increased efficiency and lower noise level. It may be possible to minimize the motor size and hence the operating expenses for high air volume systems by adopting an airfoil wheel. There is no overloading in the fan horsepower curve.

9.3 Design Parameters

Selecting a fan for an industrial dust collection system entails more than just picking a fan model. The following factors should be considered when choosing a fan:

9.3.1 Airflow Capacity

The capacity, also known as the airflow rate, is determined by the system's needs, and is measured in cubic feet per minute (CFM).

9.3.2 Static Pressure Requirements

In air handling system design, the pressure is usually expressed in inches of water column, or in-WC. This pressure is known as static pressure (SP) and is created by a fan. Static pressure values are used to overcome the system's pressure loss, which is comprised of two components: frictional resistance to airflow in the ductwork and fittings, and resistance from barriers such as dust collector, filters etc. Pressure losses are mostly caused by four factors.

- a. Hood or enclosure
- b. Ducting
- c. Housing and filters
- d. Other system components (i.e., silencer, exhaust stack, etc.)

Common factors in computing the static pressure losses are tabulated in standard texts concerning hoods and ventilation systems. To give you a better idea, I've included an example below.

9.3.3 Example

The dust collecting system has three pickup sites, represented as nodes A, G, and H in the figure below. The system flow rates in CFM, duct diameter in inches, and water column static pressure in inch of water column are all shown.

Each branch should be analyzed from its source to the system's end to calculate the system pressure losses. The system static pressure equals the branch with the highest value after all sources have been assessed. The fan system will be selected based on the total CFM from all collecting points and the highest static pressure of the line.

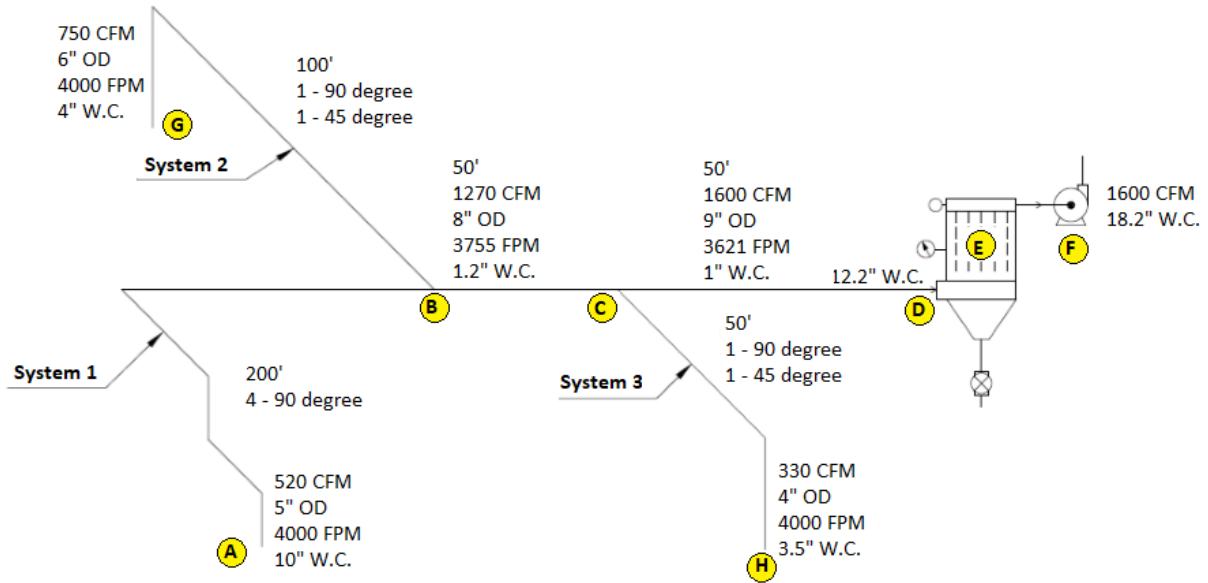

Figure 25. Dust Collecting System

Sum-total of airflow = $520 + 750 + 330 = 1600$ CFM

Static pressure:

Pressure loss in System 1, Node A – B – C – D = $10''$ wc + $1.2''$ wc + $1''$ wc = $12.2''$ wc

Pressure loss in System 2, Node G – B – C – D = $4''$ wc + $1.2''$ wc + $1''$ wc = $6.2''$ wc

Pressure loss in System 3, Node G – C – D = $3.5''$ wc + $1''$ wc = $4.5''$ wc

Select highest pressure loss is in System 1 = $12.2''$ wc

Pressure loss in Baghouse filter to Fan, Node E – F = $6''$ wc

Total Pressure Loss = $12.2''$ wc + $6''$ wc = $18.2''$ wc

9.4 Service Factors

9.4.1 Material Handled

Centrifugal fans with a backward-curved impeller are the most widely used fans in dust collectors because they cannot overload the fan motor and cause stoppages. They are rugged and provide years of trouble-free service with minimal maintenance.

If there is moisture or particulates in the air stream, the appropriate fan wheel or blade must be carefully selected, and it is dependent on the material to be conveyed. Build up or corrosion of fan wheels can lead to safety concerns, decreased performance and bearing failure due to imbalance.

9.4.2 Explosive or Flammable Material

When dealing with explosive or flammable products, always refer to the National Fire Protection Association (NFPA) standards and other regulatory requirements. Non-sparking wheel material,

fan motors as well as special bearings and controls, should be considered if there is a risk of explosion or flammability.

9.4.3 Corrosive Applications

If used in corrosive situations, a protective coating or corrosion resistant material, such as stainless steel, fiberglass, or plastic, shall be used.

9.4.4 Elevated Airstream Temperature

Because temperature affects the strength of fan materials, it's important to be aware of appropriate materials and expected airstream temperatures in worst conditions.

9.5 Fan Location

The position of the fan is also crucial. The fan should be the last part of the exhaust ventilation system between the dust collector and the exhaust stack. This layout allows practically the entire system to be kept under negative pressure in relation to the workplace, ensuring that if a leak occurs anywhere in the system, air will flow from the workplace into the duct rather than contaminated air leaking from the duct into the workplace.

9.6 Drive Arrangements

9.6.1 Power Source

All industrial fans require a power source. If electric motors are used, a variable frequency drive (VFD) can be used to control fan speed.

9.6.2 Direct Drive

Direct drive offers a constant fan speed as the fan is directly coupled to the motor. The motor rotation speed (RPM) is function of the motor construction (number of poles) and the frequency of power supply, (Hertz, Hz).

The direct drive arrangement is more compact and reduces the maintenance efforts of replacing or tightening the worn belts.

9.6.3 Belt Drive

The drive ratio allows for adjusting the fan speed. If there are changes to the process, the hood design, or the location of equipment or air cleaning equipment, the system capacity or pressure requirements may need to be adjusted. The motor for belt-driven fans can be placed in a variety of positions.

9.7 Noise

9.7.1 Sound Power and Sound Pressure

Noise level is measured in units called decibels (db). The noise level will vary depending on the speed, interconnected ductwork and point of operation. The sound pressure is a measurement affected by the fan's location and other environmental factors.

9.7.2 Contributors to Noise

- a. The type of fan, flow rate, pressure and fan efficiency contribute to the noise generated by a fan.
- b. The quietest fans are usually those with a backward impeller design.

- c. The fans noise level can be increased on any type of fan if the airflow at the fan outlet or inlet is non-uniform.
- d. Silencers or noise enclosures can be added to fans to reduce noise.
- e. For more information about noise, reference the ASHRAE Handbook – Fundamentals.

9.8 Safety and Accessories

9.8.1 Guarding

Guarding must be provided to meet statutory safety criteria and OSHA guidelines. Inlet, exit, shaft, drive, belts, and cleanout doors are all potential danger points to consider.

9.8.2 Accessories

Accessories such as drains, cleanout doors, split housings, inlet boxes and shaft seals can aid in the installation and maintenance of industrial dust collection systems.

9.9 Flow control

The strategies listed below might help you manage the flow rate of an industrial dust collection system. Properly controlled flow rates provide several benefits, including reduced energy demands.

- a. Bypass/relief damper – ZERO savings
- b. Variable outlet damper – SOME savings
- c. Variable inlet vanes – SLIGHTLY MORE savings
- d. Varying speed control of fan – BIG savings

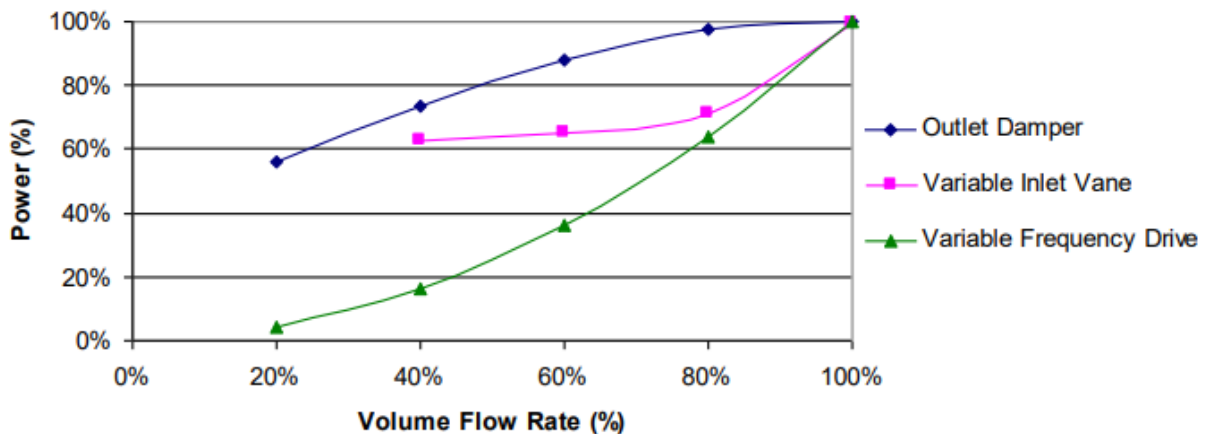

Figure 26. Flow Control

9.10 Physical Limitations

- a. Inlet size and location
- b. Outlet size and location
- c. Fan arrangement/ orientation
- d. Weight of the fan
- e. Ease of maintaining the fan
- f. The physical space available

Size and weight, energy consumption, and fan noise are all important factors to consider when choosing a fan.

Fan selection is based on calculations of the total air volume the system must handle, as well as the required static pressure to overcome all pressure losses, with a 10-20 percent margin of error for future expansion demands.

9.11 Electric motors

Electric motors are used to supply the necessary energy to drive the fan. The two most common types of motors used in dust collection systems are squirrel cage motors and wound rotor motors.

9.11.1 Squirrel-cage motors

These motors have a constant speed and are of a non-synchronous, induction type.

9.11.2 Wound-rotor motors

These motors are also known as slip-ring motors. They are general-purpose or continuous-rated motors and are chiefly used when an adjustable-speed motor is desired.

Squirrel-cage and wound-rotor motors are further classified according to the type of enclosure they use to protect their interior windings. These enclosures fall into two broad categories:

9.11.2.1 Open

Drip-proof and splash-proof motors are open motors. They provide varying degrees of protection; however, they should not be used where the air contains substances that might be harmful to the interior of the motor.

9.11.2.2 Totally Enclosed

Totally enclosed motors are weather protected with the windings enclosed. These enclosures prevent free exchange of air between the inside and the outside, but they are not airtight. Totally enclosed, fan cooled (TEFC) motors are another kind of totally enclosed motor. These motors are the most used motors in dust collection systems. They have an integral-cooling fan outside the enclosure, but within the protective shield, that directs air over the enclosure.

Both open and totally enclosed motors are available in explosion proof and dust ignition proof models to protect against explosion and fire in hazardous environments.

In the next chapter, we'll go into safety in greater detail.

10 CHAPTER – 10: DUST COLLECTOR SAFETY

Many types of dust generated by industrial processes are flammable, and when fine flammable dust goes airborne, it poses an explosion risk. According to OSHA, there have been 231 cases involving combustible dust explosions in the last 25 years, with 119 fatalities and 718 injuries. OSHA inspects businesses with a history of problems and businesses that handle combustible materials as per the Material Safety Data Sheet (MSDS). The inspectors look for:

- a. Housekeeping- dust accumulators that are 1/32" or larger and cover 5% of the floor or overhead area.
- b. Duct layout- design for correct carrying velocity.
- c. Collector- designed with explosion venting in accordance with NFPA 68.
- d. Preventative Maintenance- as specified in NFPA 69, 654, and 664.

10.1 Dust Explosion

Fire occurs when dust and air mix together in the proper quantities in the presence of an ignition source. An explosion happens when combustion occurs in a confined space, which is accompanied by an increase in pressure inside the restricted space. Simply described, the following factors are required for a dust explosion:

- a. **Combustible dust** is any fine material that can catch fire and explode when mixed with air. Sugar, plastic, flour, grain, wood, metal, carbon, and other combustible dusts are examples.
- b. **Oxidant** means presence of oxygen
- c. **Ignition source** means presence of an electrostatic discharge, an electric current arc, a glowing ember, a hot surface, welding slag, frictional heat or flame etc.
- d. **Dispersion** means the dust particles are suspended in air.
- e. **Confinement** means the dust being contained in a small or enclosed location, such as a dust collector housing, silo, or dryer.

The first line of defense to avoid baghouse fires and explosion is to ensure that your system maintains design volume and thus design duct velocity, which keeps the ducts clean. It is very difficult for a fire to sustain itself from the original heat generation source to the baghouse if there is no fuel in the bottom of the duct or adhered to the sides.

Dust evaluations should be performed on a regular basis to identify the specific areas of production that are susceptible to dust accumulation. A proper examination of the dust is the most important component in establishing the optimum way of dust explosion prevention. Dust samples should be examined by a qualified lab to establish the severity of the dust explosion and the minimum ignition concentration for an explosion.

Tests performed in accordance with ASTM E1226, Standard Test Method for Pressure and Rate of Pressure Rise for Combustible Dusts, will reveal details about your dust's explosible characteristics.

10.2 Technologies for Explosion Protection

There are many types of devices and systems used to comply with NFPA standards for the explosion protection of dust collection systems, but they fall into two broad categories: passive and active.

- a. Passive systems react to the event. The goal of a passive system is to control an explosion to keep occupants safe and minimize equipment damage in the plant.
- b. Active systems by contrast, detect and react prior to or during the event. Active systems involve much more costly technology and prevent an explosion from occurring. It typically requires re-certification every three months.

10.3 Passive Systems

10.3.1 Explosion Panels/Vents

- a. Explosion panels, also referred to as explosion vents, are the most widely used method for mitigating or safely redirecting dust explosions. An explosive vent opens when the collector's interior exceeds a predetermined pressure, allowing the excess pressure and flame front to depart to a safe region. It is designed to be the "weak" link of the dust collector vessel. These can be provided on ducts as well as on collector housings.
- b. Explosion relief vents are an effective means for explosion protection when your dust collector or vessel is located outdoors or near an outside wall when located indoors.
- c. If a dust collector must be installed inside a building, a vent duct must be installed to convey vented material from the dust collector to the outside.
 - A vent duct's cross-sectional area must be at least as large as the vent itself, but no more than 150 percent of the vent's cross-sectional area at any point in the vent duct.
 - Vent ducts must be noncombustible and sturdy enough to bear the predicted maximum pressure in a vented enclosure during a vented deflagration.
 - Bends in the vent duct are now allowed, but “support calculations shall include reaction forces based on the expected maximum pressure developed in a vented enclosure during a vented deflagration.
- d. Follow NFPA 68 for explosion venting calculations.



EXPLOSION PANEL

Figure 27. Explosion Panel

10.3.2 Flameless venting

A flameless vent, which is designed to be installed over a standard explosive vent, extinguishes the flame front as it exits the vented area, preventing it from exiting the device. This allows for conventional venting to take place indoors, where it may otherwise endanger people or cause secondary explosions.



Figure 28. Flameless Venting Device

10.3.3 Burst Indicators

Burst indicators are positioned on the explosion panels to alert operators of the occurrence of an event. When activated, the indicator transmits a signal to a central control panel, which then turns on a light, an alarm, or the automation system.

10.3.4 Passive float valve

Float valve utilizes a mechanical barrier to isolate pressure and flame fronts caused by the explosion from spreading further through the ducting. It is intended to be fitted in a dust collection system's outlet ducting. The mechanical barrier reacts within milliseconds and is closed by the pressure of the explosion.

10.3.5 Back draft damper

A mechanical back draft damper is installed in the inlet ducting. It makes use of a mechanical barrier that is held open by the process air and slammed shut by the explosion's pressure forces. This barrier prevents pressure and flame fronts from propagating further up the process stream when it is closed.

10.3.6 Flame Front Diverters

These devices direct the flame front away from the downstream pipes and towards the atmosphere. These devices are typically used between two separate vessels, each with its own explosion prevention system. The flame front diverter is designed to prevent “flame jet ignition” between the two vessels, which could overpower the installed protection mechanisms.

10.4 Active Systems

Active systems, which are more complex and expensive than passive technologies, foresee events and act before they happen. The following are examples of active systems:

10.4.1 Fire Isolation System

When the system senses a spike in pressure or flames within the ducts, it releases a chemical that extinguishes the flames and stops the explosion from spreading. This device can be put in either inlet or outlet ducting and is designed to react within milliseconds of sensing an explosion. Typical components include explosion pressure detector(s), flame detector, and a control panel.

10.4.2 Fire Suppression System

Fire suppression devices work much like fire isolation systems, except they detect pressure in the dust collection system rather than the ducts. A similar chemical agent is released to suppress the spread of an explosion and flames. It is often used, together with isolation, when it is not possible to safely vent an explosion or where the dust is harmful or toxic.

10.4.3 Introduce Inert Gas systems

Inert dust introduced into a system will eliminate the lower explosive limit (LEL) of the dust mixture, resulting in a mixture that will not explode. This is especially effective when the dust concentration is very low. A comparable technique is to mix a combustible gas with another gas stream that has already oxidized, so it is not combustible. Carbon dioxide (CO₂), nitrogen (N₂), and argon (Ar) are all inert gases that can help reduce oxygen levels in dust collection systems. Inert gas systems are also a practical alternative to having to install deflagration vents on dust collector housings. In general, if the oxygen content of combustible organic compounds is less than 8%, flame propagation is improbable.

10.4.4 Fast Acting Float Valve

The valve can be installed in either inlet or exhaust ducting and is designed to close within milliseconds of detecting an explosion. It creates a mechanical barrier within the ducting that effectively isolates pressure and flame fronts coming from either direction, preventing them from propagating further through the process.

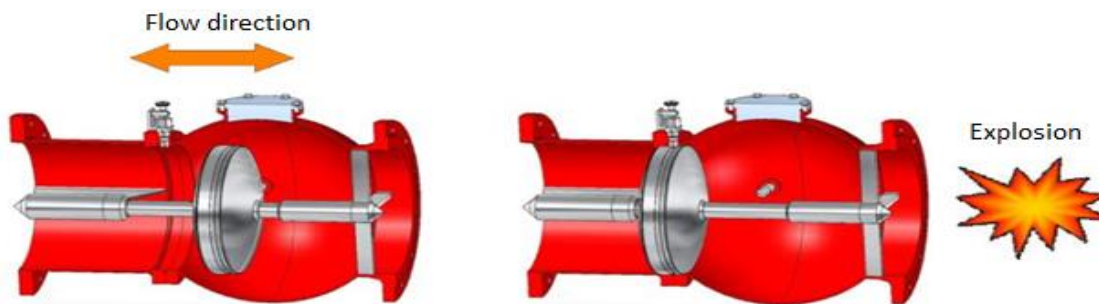
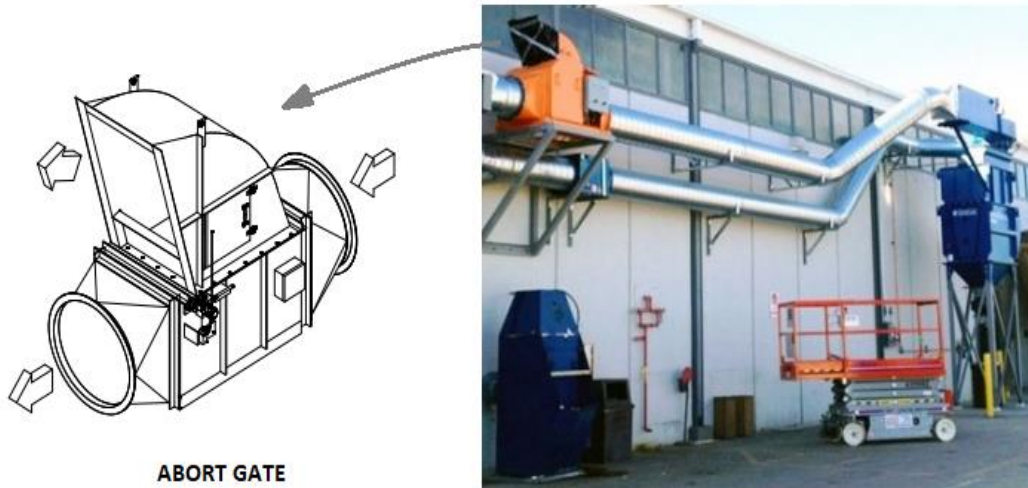

Figure 29. Fast Acting Float Valve

10.4.5 High-speed Abort Gate

The gate is used to divert possible ignition dangers from entering the collector, preventing an explosion, and preventing flame and burning debris from entering the facility through the return air system. It is installed in the inlet and/or outlet ducting of a dust collection system. Process air is diverted to a safe location via a mechanical barrier. Abort gates are activated by a spark detection system located far enough upstream to allow time for the gate to activate.



ABORT GATE

10.4.6 Fire Curtains or Shutters

Fire curtains or shutters are engineered to break fires in dust collecting ductwork.

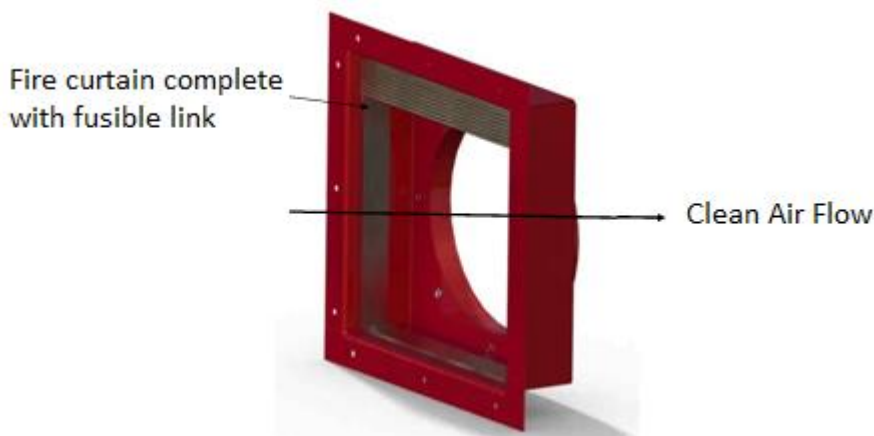

Figure 30. Fire Curtain

10.4.7 Spark Detection System

The early identification of sparks is a preventative measure against fires and explosions. A spark detector is an infrared detector that responds to rapid changes in an optical field and is particularly well suited for examining a cross section of a duct where the particles are visible for only a short time. To ensure that an entire cross section of the transport zone is fully monitored, two detectors are usually necessary. A spark detection system is commonly used in pneumatic transport of combustible particles (e.g., wood chips, cellulose fibers, sawdust, chemical dusts, and any other flammable material) where combustion or explosions are a possibility.



Figure 31. Spark Detection System

When a spark is detected, a water curtain is created in the duct in a fraction of a second, successfully extinguishing the sparks. Deluge valves, alarms, abort gates, flow diversion gates, and automatic equipment shutdown can all be programmed into the system. Because the air velocity in the duct is very high, the speed of the spark is likewise very high. Readers should consult “Hansentek” for detectors calculations, sensitivity, and interface applications.

10.5 Other Methods of Protection

Other methods for decreasing and confining the fire and explosion include using one or more of the following strategies:

10.5.1 Dust Collector Design and Construction

Where flammable dust is a concern, the dust collector housing should be constructed of thick-gauge metals with high vessel strength to withstand and reduce the severity of a blast. Alternatively, collectors can be strengthened and reinforced to withstand higher pressures, allowing for more effective explosion venting. Cylindrical collectors are more resistant to damage than rectangular collectors, but rectangular units can be braced to withstand higher explosive pressures.

10.5.2 Equipment Grounding

Grounding is required for all equipment, including housing, filters, bags, fans, ducting, and any other piece of equipment that is likely to accumulate electrostatic charges. Most often, the dust that holds a charge insulates the static charge from the containment bag. Sparks can be generated when the filter element is cleaned. Baghouses are also known for being difficult to ground since the metal cages carrying the filter elements frequently do not make sufficient contact with the metal frame that holds the filter bags in place. Filter bags for metal-based dusts should be lined with copper wire to minimize the accumulation of electric charges.

10.5.3 Ductwork Protection

Non-metallic ducts or conduits should not be used for dust conveyance because they tend to develop static charges, even if they are sprinkler protected. Stainless steel ducting is the finest option, especially in settings where corrosion is a problem.

The NFPA mandates that the ductwork and safety processes upstream of the dust collector be protected. Equip the ducting with a flow-activated isolation valve protecting downstream work areas and processes from the propagation of flame and pressure through the inlet duct when deflagration occurs in a dust collector.

10.5.4 Dust Explosion Venting

Explosion vent ducts should be terminated in an outdoor location to safely direct the flames, gases, and debris from the dust collector away from persons and property to the outside of the building. Dust explosion vent ducts should be kept as short and straight as feasible, with a maximum length of 20 feet. Any changes in vent duct direction increases the overpressure developed during venting. In all cases, the vent duct must be made as strong as the dust collector.

Using explosive vent ducts during venting will significantly increase the pressure in the dust collector. The vent duct must have a cross-section at least as great as that of the vent itself. A vent duct with a cross-section larger than that of the vent will result in a smaller increase in the maximum pressure produced during venting. Equipment or enclosures that must sustain more than 1.5 psig pressure must comply with NFPA 68, Venting of Deflagrations. During an explosion, the maximum pressure reached will always be greater than the pressure at which the vent device releases. According to NFPA 68, the pressure differential between the vent release pressure and the dust collector's resistive pressure (enclosure) must be at least 0.35 psi.

10.5.5 Hopper Protection

When dust sits in a hopper for an extended period, it can cause a fire or explosion. If a hopper is not cleaned out before the fan is turned off, a fire can start. An explosion could occur if a hopper door is opened. In cases where operating personnel have tried to put out a hopper fire with a hose, the water stream agitated the dust forming a dust cloud that passed through the LEL. The fire in the hopper serves as a detonation source and a serious explosion. In such circumstances, injecting inert gas into the collector and allowing it to cool below ignition temperatures is the best approach.

10.6 NFPA Codes and Standards

The National Fire Protection Association (NFPA) has issued several publications related to the prevention of industrial dust explosions.

10.6.1 NFPA 654, “Standard for the Prevention of Fire and Dust Explosions”

This is an all-encompassing standard on how to design a safe dust collection system. It is regarded as the guiding dust document and the most general on the topic, and it will lead you to other relevant documents. Some highlights from this standard are:

- a. A continuous industrial exhaust system shall be installed for processes where combustible dust is liberated in normal operations.

- b. The industrial exhaust system shall incorporate a dust collector. Industrial exhaust system components including the ductwork and dust collector must be so constructed such that dust does not leak out of the system components when the system is shut down.
- c. The dust control system shall comply with the requirements of NFPA 91, Standard for Exhaust Systems for Air Conveying of Materials.
- d. Dust collectors for industrial dust control shall be located outside of buildings. Dust collectors may be located inside of buildings if they are located near an outside wall, are vented to the outside through straight reinforced ducts not exceeding 10 feet in length and have explosion vents designed according to information in NFPA 68, Venting of Deflagrations. Some think that installing an explosion vent on a dust collector prevents an explosion. This is not the case. The vent relieves the pressure of an explosion. Dust collectors can be installed safely inside buildings only under one of the following conditions:
 - The dust collector is protected by an explosion suppression system meeting the requirements of NFPA 69, Explosion Prevention Systems.
 - The dust collector has an explosion relief vent meeting the requirements of NFPA 68, Venting of Deflagrations, and the vent is properly ducted in accordance with NFPA 68 through a nearby outside wall.

10.6.2 NFPA 68, “Guide for Venting of Deflagrations”

This NFPA 68 standard lists the following basic principles that are common to the venting of deflagrations. You should become familiar with these principles so that you can correctly specify the conditions the dust collector and explosion vent must satisfy. Some highlights from this standard are:

- a. The vent design must be sufficient to prevent deflagration pressure inside the dust collector from exceeding two-thirds of the ultimate strength of the weakest part of the dust collector, which must not fail. This criterion does anticipate that the dust collector may deform. So do expect some downtime with the dust control system after an explosion.
- b. Dust vent explosion operation must not be affected by snow, ice, sticky materials, or similar interferences.
- c. Dust explosion vent closures must have a low mass per unit area to reduce opening time. NFPA recommends a maximum total mass divided by the area of the vent opening of 2.5 lbs/ft².
- d. To shorten opening time, dust explosion vent closures must have a low mass per unit area. NFPA 68 prescribes a maximum mass per unit area of 2.5 lbs/ft² for vent openings.
- e. Dust explosion vent closures should not become projectiles because of their operation. The closure should be properly restrained without affecting its function.
- f. Vent closures must not be affected by the process conditions which it protects or by conditions on the non-process side.
- g. Explosion vent closures must release at overpressures close to their design release pressures. Magnetic or spring-loaded closures will satisfy this criterion when properly designed.
- h. Explosion vent closures must reliably withstand fluctuating pressure differentials that are below the design release pressure.
- i. Dust explosion vent closures must be inspected and properly maintained in order to ensure dependable operation. In some cases, this may mean replacing the vent closure at suitable time intervals.

- j. The supporting structure for the dust collector must be strong enough to withstand any reaction forces developed because of operation of the dust explosion vent.
- k. Industrial exhaust system ductwork connected to the dust collector may also require explosion venting.

10.6.3 NFPA 69 “Explosion Prevention Systems”

This standard cover explosion protection of dust collectors when venting is not possible. It covers the following methods for prevention of deflagration explosions: control of oxidant concentration, control of combustible concentration, explosion suppression, deflagration pressure containment, and spark extinguishing systems.

10.6.4 NFPA 91 “Exhaust Systems for Air Conveying Materials”

This standard provides minimum requirements for the design, construction, installation, operation, testing, and maintenance of exhaust systems for air conveying of vapors, gases, mists, and noncombustible particulate solids except as modified or amplified by other applicable NFPA standards.

Note that NFPA standards are adopted by OSHA as consensus standards and can be mandated by an authority having jurisdiction (AHJ), such as a plant owner, insurance provider, fire chief or building inspector.

Summary

Dust collecting systems are invaluable for several reasons. First, they reduce pollution and potential for pollution. Likewise, they reduce unpleasant odors, especially in industrial settings, and generally improve environmental quality. They also improve the safety of work environments by improving visibility.

It is important to check all your dust collection components when experiencing airflow or dusting problems. Your collector needs to provide enough airflow (CFM), velocity (FPM) and limit static pressure (SP). The air travelling through the ducts must maintain enough velocity to keep the dust in the airstream—that’s 3500 to 4,000 FPM. If velocity diminishes, the debris will fall out of the airstream and build up inside the ducts. Decreasing duct size improves velocity but also increases friction, or static pressure (SP), which affects the volume (CFM) of air being moved. Try to take a direct route to the dust pick-up points, avoid tees and hard 90-degree elbows, and limit curves, bends and flex hoses.

The process gas inlet characteristics especially temperature and the type of particulates are key to determining the filter media and special treatments. Non-woven fabrics are the more common, with polyester being the most versatile material. They serve operating temperatures below 275°F (most applications fall under this figure; higher temperatures require more specialized materials). Full polyester, blended polyester, Gore-Tex, Teflon, cellulose and treated cellulose are some of the options available.

Each design poses unique challenges—there is no cookie-cutter solution. You should build a system that works for your facility and remains in budget.

References

- EPA Air Pollution Control Cost Manual, sixth edition (January 2002), prepared by the Air Quality Strategies and Standards Division of the Office of Air Quality Planning and Standards, U.S. Environmental Protection Agency, Research Triangle Park, NC 27711.
- Baghouse Plan Review, Student Guidebook, APTI Course SI:412 (April 1982) by Air Pollution Training Institute, United States Environmental Protection Agency.
- Control of Particulate Matter Emissions, Student Manual, APTI Course 413, Third Edition (January 2000) by Air Pollution Training Institute, United States Environmental Protection Agency.
- Pulse Jet Filter Operation and Maintenance Manual by AIRLANCO (www.airlanco.com)
- Baghouse Accessories by General Electric Company (www.ge-energy.com/airquality)
- Particulate Matter Controls (<https://www.epa.gov>)
- Baghouse Filter Basics (<https://www.nfm-filter.com> and <https://www.iaom.org>)

Annexure -1

Typical A/C ratios (CFM/ft²) for selected industries

Industry	Fabric filter air-to-cloth ratio		
	Reverse air	Pulse jet	Mechanical shaker
Basic oxygen furnaces	1.5-2	6-8	2.5-3
Brick manufacturing	1.5-2	9-10	2.5-3.2
Castable refractory's	1.5-2	8-10	2.5-3
Clay refractory's	1.5-2	8-10	2.5-3.2
Coal-fired boilers	1-1.5	3-5	-
Detergent manufacturing	1.2-1.5	5-6	2-2.5
Electric arc furnaces	1.5-2	6-8	2.5-3
Feed mills	-	10-15	3.5-5
Ferroalloy plants	2	9	2
Glass manufacturing	1.5	-	-
Grey iron foundries	1.5-2	7-8	2.5-3
Iron and steel (sintering)	1.5-2	7-8	2.5-3
Lime kilns	1.5-2	8-9	2.5-3
Municipal and medical waste incinerators	1-2	2.5-4	-
Petroleum catalytic cracking	-	-	-
Phosphate fertilizer	1.8-2	8-9	3-3.5
Phosphate rock crushing	-	5-10	3-3.5
Polyvinyl chloride production	-	7	-
Portland cement	1.2-1.5	7-10	2-3
Pulp and paper (fluidized bed reactor)	-	-	-
Secondary aluminum smelters	-	6-8	2
Secondary copper smelters	-	6-8	-

Source: EPA

Annexure -2

Glossary of Useful Terms

1. **Agglomeration:** Multiple particles joining or clustering together by surface tension to form larger particles, usually held by moisture, static charge or particle architecture.
2. **Air Pollution:** The presence of any substance in lower levels of the atmosphere, other than moisture, in concentrations high enough to adversely affect the health of any living organism. Air pollutants include suspended dusts, aerosols, fumes, or any gaseous compounds (usually sulfur, nitrogen, or carbon) that result from a manufacturing process.
3. **Air to Cloth/Fabric Ratio:** It is the volumetric air/gas flow rate entering the baghouse divided by the total effective area of the filter bags. It is often referred to as filter/filtration velocity. It is the velocity at which air passes through the filter media, or rather the velocity that air approaches the media.
4. **Blinding (or plugging):** The loading, or accumulation, of a dust cake on a filter bag to the degree that the dust cake cannot be dislodged by the cleaning mechanism of the filter. The efficiency of a baghouse with blinded bags is significantly diminished due to a sharp increase in the static pressure drop of the air passing through the bags.
5. **Blowpipe (or Manifold):** In compressed air baghouses, a pipe in the plenum section that runs horizontally several inches over the tube sheet with a hole/orifice over each bag; responsible for distributing the compressed air pulses to each bag.
6. **Cage:** A wire structure used to support filter bags in a pulse jet baghouse.
7. **Carrying Velocity (or Transport Velocity):** The gas/air velocity in a duct required to keep the transported material suspended, usually between 3500 and 4000 feet per minute (1067 and 1219 meters per minute), varying according to the type of material being conveyed. Ducts with a velocity lower than 3500 fpm (1067 m/min.) could allow material to settle out and cause buildup in the duct. Ducts with velocities higher than 4000 fpm (1219 m/min.) can lead to abrasion of the ductwork.
8. **Cell Plate (Tube sheet):** Internal divider surface that separates dirty from clean gas plenums and where the bags are seated.
9. **Clean on Demand:** The process of cleaning bags based on differential pressure as opposed to a timer.

10. **Compartment:** A segmented filtering section of a baghouse that can be isolated from the others.
11. **Condensation:** The process of changing matter from a vapor state into a liquid state, usually by the extraction of heat.
12. **Dehumidify:** To reduce by any process, the quantity of water vapor.
13. **Diaphragm Valve:** A pneumatically operated valve (with a diaphragm) that allows a pulse of compressed air to travel from the header to the blowpipes in a compressed air baghouse.
14. **Differential Pressure, ΔP :** The resistance to flow across (through) a baghouse, measured in “inches of water” column or “inches H₂O.”
15. **Dust:** Small solid particles having a width between 1 micron and 100 microns, created by breaking up of larger particles (through processes such as grinding, drilling, explosion, crushing, etc.).
16. **Dust Loading:** The weight of solid particulates suspended in an air or gas stream, usually expressed in terms of grains per cubic foot, grams per cubic meter, pounds per thousand pounds of gas, or parts per million.
17. **Emission Standard:** The maximum legal concentration or rate at which air pollutants may be discharged from a single source; may include mandatory guidelines concerning types of emission control equipment that must be used.
18. **Filter (or Air Filter):** Any device, manual or automatic, whose function is the separation of air pollutants (such as dusts, suspended particulates, aerosols, fumes, or smoke) from an airstream; sometimes used to refer to only the filtering element, such as a bag.
19. **Filter Cake:** The thin layer of dust that builds on the surface of a bag or filter medium during the filtration process.
20. **Flex Failure:** Caused by excessive movement, such as under-tensioning or over-cleaning.
21. **Grain:** Small unit of mass, used frequently in describing air pollutant concentrations, equal to 1/7000 pound (approximately 64.8 milligrams).
22. **Hopper Baffle:** A device located in the baghouse hopper to help evenly distribute the air and dust flow into the bags. May also act to knock out big particles.
23. **Impingement:** The act of particulate striking the bags and becoming attached.

24. **Inch of Water:** A unit of pressure (often abbreviated "wg") equal to the pressure exerted by a column of liquid water one-inch-high at a standard temperature (usually 70°F). For conversions, 1.000 psi = 27.71" wg.
25. **Interstices:** The open voids in the filter bag's cloth where air passes through.
26. **Magnehelic Gauge:** Used to measure differential pressure (in inches of water).
27. **Mullen Burst Test:** An ASTM rupture test for measuring the strength of filter bag material, using PSI/square inches of material.
28. **Needled Felt:** A felt held together by interlocking adjacent fibers, manufactured by using barbed needles to push and pull loose fibers together. Needled felt is stronger than pressed felt.
29. **Null Period (Settling Time):** A time segment during off line cleaning when the bags are allowed to relax without any cleaning energy supplied. This allows the displaced dust to fall off the bags and settle below the inlet opening.
30. **Opacity:** A term to describe the percentage of light that cannot pass through an object; may be used to describe the degree of visibility of an exhaust plume.
31. **Particulate:** Any type solid or liquid particle suspended in the air that is usually considered an undesirable air pollutant; includes all types of dusts, fly ash, pollen, smoke and fume particles, and aerosols.
32. **Permeability, Fabric (or Cloth Permeability):** The ability of air to pass through the fabric, given a 0.50" wg pressure differential. Fabric permeability is expressed in units of cfm per square foot of fabric and measured most often with a Frazier porosity meter or a Gurley permeometer.
33. **Pilot Valve:** A normally-closed, two-way solenoid valve which transforms an electrical signal into a pneumatic signal for pulling air away from one side of a normally-closed diaphragm valve on the pressurized air supply line for a compressed air (pulse jet) baghouse. This action allows the diaphragm to move away from its seal, allowing compressed air to move unobstructed from the header through the valve and into the blowpipes.
34. **Plume:** The path taken by the gas discharge from a smoke stack or chimney.
35. **PM10:** The concentration of suspended air particulates that are 10 microns in diameter or smaller; the class of air pollutants that are the most harmful to the respiratory system of humans.

36. **Porosity, Fabric:** Percentage of voids per unit volume of fabric, not to be confused with fabric permeability.
37. **PPM (Parts Per Million):** A mass ratio often used to describe small concentration of toxic air pollutants; gives pounds of pollutant per million pounds of air.
38. **Pressure, Gage:** Pressure measured relative to atmospheric pressure, may be either positive or negative.
39. **Pulse Cycle:** In compressed air baghouses, the interval between the time a pitot valve allows a pulse of compressed air to enter through a diaphragm valve into a blowpipe and the time the next pitot valve in the sequence performs the same operation. Pulse cycles generally range from 5 to 30 seconds but may be much higher.
40. **Pulse Duration:** In compressed air baghouses, the interval of time that the electrical signal necessary to open a pitot valve remains active. The duration of this electric signal most often ranges between 50 and 500 milliseconds; but because of a slow response time, the diaphragm valve may remain open for up to four or five times longer.
41. **Re-entrainment:** The occurrence where dust is collected from the airstream but then returned to the airstream from the same device. This term is used to refer to the situation in baghouses where dust particles on the surface of the filter media are forced back into the air when the bags are cleaned.
42. **Smoke:** An air suspension (aerosol) of solid carbon particles, 0.1 microns or smaller in diameter, originating from an incomplete combustion process of carbon-based materials such as coal, oil, tar, and tobacco.
43. **Solenoid Valve:** An electromagnetic pilot valve used to activate a diaphragm valve on a pulse jet baghouse.
44. **Tube Sheet (Cell Plate):** Internal divider surface that separates dirty from clean gas plenums and where the bags are seated.
45. **Vapor:** The gaseous form of substances which are normally in a liquid or solid phase at standard atmospheric conditions. This change of state is accomplished by either raising the temperature or lowering the pressure.
46. **Venturi:** A device shaped like a converging-diverging nozzle inserted through the top of the bag openings in the tube sheet in some compressed air baghouses and used to increase the effectiveness of the compressed air blasts.

47. **Weight:** Bags are selected based on average weight per square foot.